

3

Product Design for Manual Assembly

3.1 INTRODUCTION

Design for assembly (DFA) should be considered at all stages of the design process, but especially the early stages. As the design team conceptualizes alternative solutions, it should give serious consideration to the ease of assembly of the product or subassembly. The team needs a DFA tool to effectively analyze the ease of assembly of the products or subassemblies it designs. The design tool should provide quick results and be simple and easy to use. It should ensure consistency and completeness in its evaluation of product assemblability. It should also eliminate subjective judgment from design assessment, allow free association of ideas, enable easy comparison of alternative designs, ensure that solutions are evaluated logically, identify assembly problem areas, and suggest alternative approaches for simplifying the product structure—thereby reducing manufacturing and assembly costs.

By applying a DFA tool, communication between manufacturing and design engineering is improved, and ideas, reasoning, and decisions made during the design process become well documented for future reference.

The *Product Design for Assembly* handbook [1] originally developed as a result of extensive university research, and, more recently, expanded versions in software form provide systematic procedures for evaluating and improving product design for ease of assembly. This goal is achieved by providing assembly information at the conceptualization stage of the design process in a logical and organized fashion. This approach also offers a clearly defined procedure for evaluating a design with respect to its ease of assembly. In this manner a feedback loop is provided to aid designers in measuring improvements resulting from

specific design changes. This procedure also functions as a tool for motivating designers; through this approach they can evaluate their own designs and, if possible, improve them. In both cases, the design can be studied and improved at the conceptual stage when it can be simply and inexpensively changed. The DFA method accomplishes these objectives by:

1. Providing a tool for the designer or design team which assures that considerations of product complexity and assembly take place at the earliest design stage. This eliminates the danger of focusing exclusively during early design on product function with inadequate regard for product cost and competitiveness.
2. Guiding the designer or design team to simplify the product so that savings in both assembly costs and piece parts can be realized.
3. Gathering information normally possessed by the experienced design engineer and arranging it conveniently for use by less-experienced designers.
4. Establishing a database that consists of assembly times and cost factors for various design situations and production conditions.

The analysis of a product design for ease of assembly depends to a large extent on whether the product is to be assembled manually, with special-purpose automation, with general-purpose automation (robots), or a combination of these. For example, the criteria for ease of automatic feeding and orienting are much more stringent than those for manual handling of parts. In this chapter we shall introduce design for manual assembly, since it is always necessary to use manual assembly costs as a basis for comparison. In addition, even when automation is being seriously considered, some operations may have to be carried out manually, and it is necessary to include the cost of these in the analysis.

3.2 GENERAL DESIGN GUIDELINES FOR MANUAL ASSEMBLY

As a result of experience in applying DFA it has been possible to develop general design guidelines that attempt to consolidate manufacturing knowledge and present them to the designer in the form of simple rules to be followed when creating a design. The process of manual assembly can be divided naturally into two separate areas, handling (acquiring, orienting and moving the parts) and insertion and fastening (mating a part to another part or group of parts). The following design for manual assembly guidelines specifically address each of these areas.

3.2.1 Design Guidelines for Part Handling

In general, for ease of part handling, a designer should attempt to:

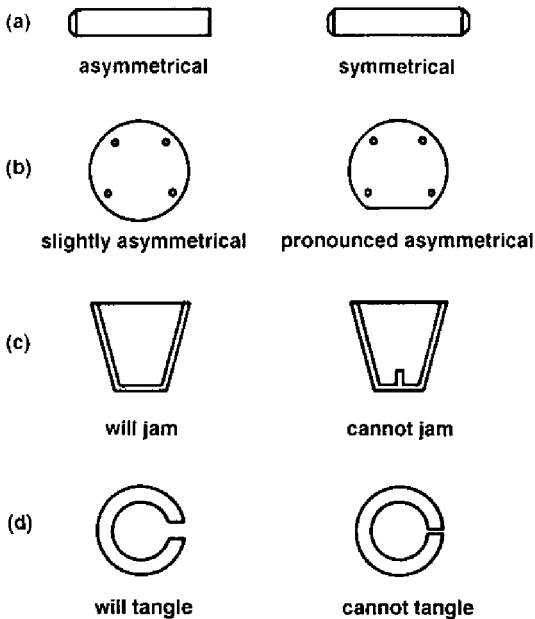

FIG. 3.1 Geometrical features affecting part handling.

1. Design parts that have end-to-end symmetry and rotational symmetry about the axis of insertion. If this cannot be achieved, try to design parts having the maximum possible symmetry (see Fig. 3.1a).
2. Design parts that, in those instances where the part cannot be made symmetric, are obviously asymmetric (see Fig. 3.1b).
3. Provide features that will prevent jamming of parts that tend to nest or stack when stored in bulk (see Fig. 3.1c).
4. Avoid features that will allow tangling of parts when stored in bulk (see Fig. 3.1d).
5. Avoid parts that stick together or are slippery, delicate, flexible, very small, or very large or that are hazardous to the handler (i.e., parts that are sharp, splinter easily, etc.) (see Fig. 3.2).

3.2.2 Design Guidelines for Insertion and Fastening

For ease of insertion a designer should attempt to:

1. Design so that there is little or no resistance to insertion and provide chamfers to guide insertion of two mating parts. Generous clearance

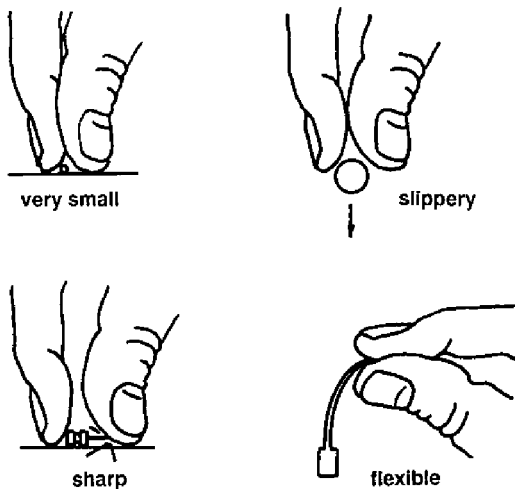

FIG. 3.2 Some other features affecting part handling.

should be provided, but care must be taken to avoid clearances that will result in a tendency for parts to jam or hang-up during insertion (see Figs. 3.3 to 3.6).

2. Standardize by using common parts, processes, and methods across all models and even across product lines to permit the use of higher volume processes that normally result in lower product cost (see Fig. 3.7).
3. Use pyramid assembly—provide for progressive assembly about one axis of reference. In general, it is best to assemble from above (see Fig. 3.8).
4. Avoid, where possible, the necessity for holding parts down to maintain their orientation during manipulation of the subassembly or during the placement of another part (see Fig. 3.9). If holding down is required, then try to design so that the part is secured as soon as possible after it has been inserted.
5. Design so that a part is located before it is released. A potential source of problems arises from a part being placed where, due to design constraints, it

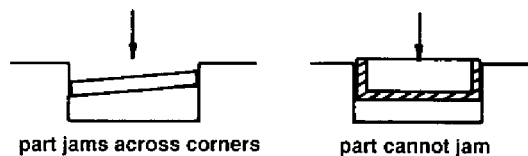

FIG. 3.3 Incorrect geometry can allow part to jam during insertion.

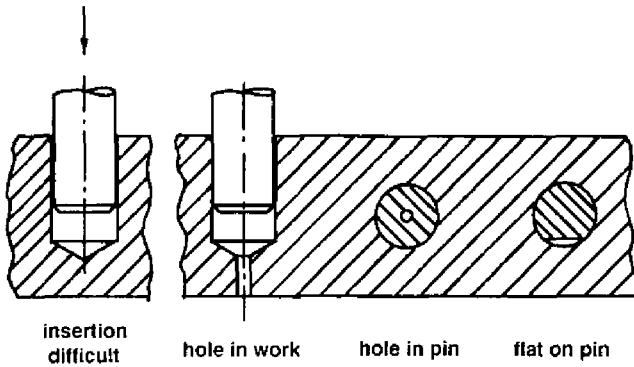

FIG. 3.4 Provision of air-relief passages to improve insertion into blind holes.

must be released before it is positively located in the assembly. Under these circumstances, reliance is placed on the trajectory of the part being sufficiently repeatable to locate it consistently (see Fig. 3.10).

- When common mechanical fasteners are used the following sequence indicates the relative cost of different fastening processes, listed in order of increasing manual assembly cost (Fig. 3.11).

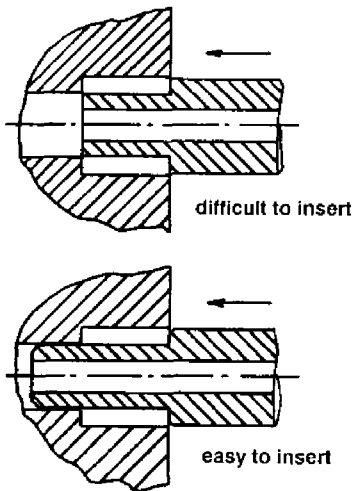

FIG. 3.5 Design for ease of insertion—assembly of long stepped bushing into counter-bored hole.

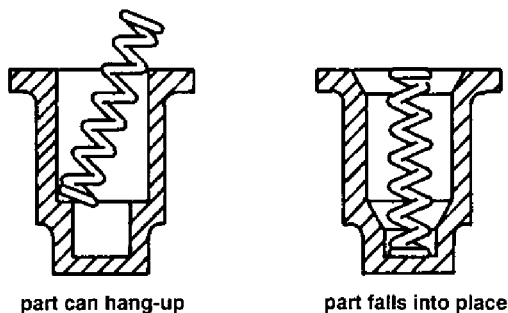

FIG. 3.6 Provision of chamfers to allow easy insertion.

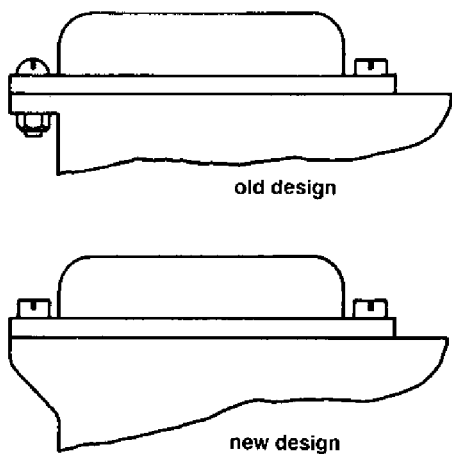

FIG. 3.7 Standardize parts.

- a. Snap fitting
 - b. Plastic bending
 - c. Riveting
 - d. Screw fastening
7. Avoid the need to reposition the partially completed assembly in the fixture (see Fig. 3.12).

Although functioning well as general rules to follow when design for assembly is carried out, guidelines are insufficient in themselves for a number of reasons.

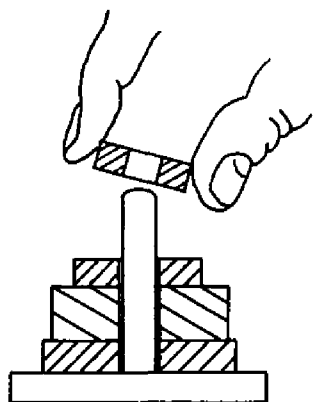

FIG. 3.8 Single-axis pyramid assembly.

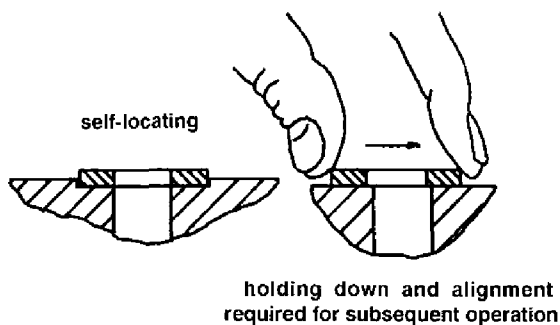

FIG. 3.9 Provision of self-locating features to avoid holding down and alignment.

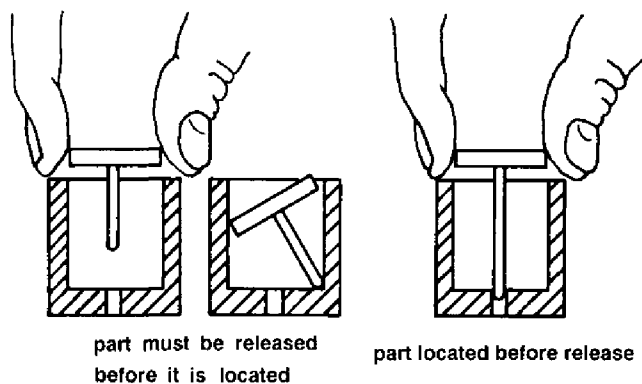

FIG. 3.10 Design to aid insertion.

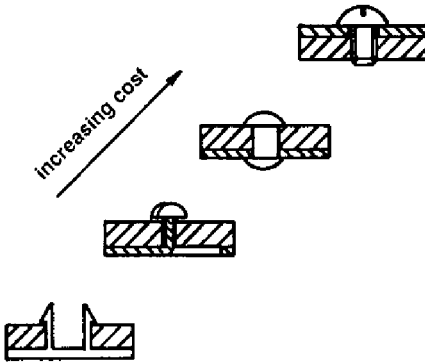

FIG. 3.11 Common fastening methods.

First, guidelines provide no means by which to evaluate a design quantitatively for its ease of assembly. Second, there is no relative ranking of all the guidelines that can be used by the designer to indicate which guidelines result in the greatest improvements in handling, insertion, and fastening; there is no way to estimate the improvement due to the elimination of a part, or due to the redesign of a part for handling, etc. It is, then, impossible for the designer to know which guidelines to emphasize during the design of a product.

Finally, these guidelines are simply a set of rules that, when viewed as a whole, provide the designer with suitable background information to be used to develop a design that will be more easily assembled than a design developed without such a background. An approach must be used that provides the designer with an organized method that encourages the design of a product that is easy to assemble. The method must also provide an estimate of how much easier it is to assemble one design, with certain features, than to assemble another design with different features. The following discussion describes the DFA methodology, which provides the means of quantifying assembly difficulty.

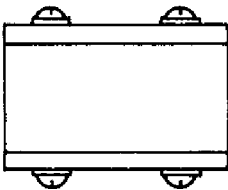

FIG. 3.12 Insertion from opposite direction requires repositioning of assembly.

3.3 DEVELOPMENT OF THE SYSTEMATIC DFA METHODOLOGY

Starting in 1977, analytical methods were developed [2] for determining the most economical assembly process for a product and for analyzing ease of manual, automatic, and robot assembly. Experimental studies were performed [3–5] to measure the effects of symmetry, size, weight, thickness, and flexibility on manual handling time. Additional experiments were conducted [6] to quantify the effect of part thickness on the grasping and manipulation of a part using tweezers, the effect of spring geometry on the handling time of helical compression springs, and the effect of weight on handling time for parts requiring two hands for grasping and manipulation.

Regarding the design of parts for ease of manual insertion and fastening, experimental and theoretical analyses were performed [7–11] on the effect of chamfer design on manual insertion time, the design of parts to avoid jamming during assembly, the effect of part geometry on insertion time, and the effects of obstructed access and restricted vision on assembly operations.

A classification and coding system for manual handling, insertion, and fastening processes, based on the results of these studies, was presented in the form of a time standard system for designers to use in estimating manual assembly times [12,13]. To evaluate the effectiveness of this DFA method the ease of assembly of a two-speed reciprocating power saw and an impact wrench were analyzed and the products were then redesigned for easier assembly [14]. The initial design of the power saw (Fig. 3.13) had 41 parts and an estimated assembly time of 6.37 min. The redesign (Fig. 3.14) had 29 parts for a 29% reduction in part count, and an estimated assembly time of 2.58 min for a 59% reduction in assembly time. The outcome of further analyses [14] was a more than 50% savings in assembly time, a significant reduction in parts count and an anticipated improvement in product performance.

3.4 ASSEMBLY EFFICIENCY

An essential ingredient of the DFA method is the use of a measure of the DFA index or “assembly efficiency” of a proposed design. In general, the two main factors that influence the assembly cost of a product or subassembly are

The number of parts in a product.

The ease of handling, insertion, and fastening of the parts.

The DFA index is a figure obtained by dividing the theoretical minimum assembly time by the actual assembly time. The equation for calculating the DFA index E_{ma} is

$$E_{ma} = N_{min}t_a/t_{ma} \quad (3.1)$$

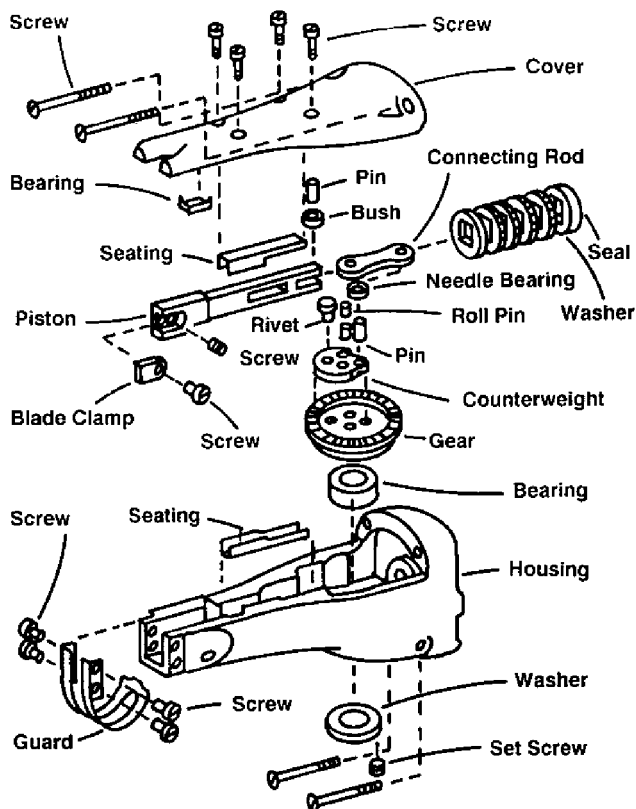

FIG. 3.13 Power saw (initial design—41 parts, 6.37 min assembly time). (After Ref. 14.)

where N_{\min} is the theoretical minimum number of parts, t_a is the basic assembly time for one part, and t_{ma} is the estimated time to complete the assembly of the product. The basic assembly time is the average time for a part that presents no handling, insertion, or fastening difficulties (about 3 s).

The figure for the theoretical minimum number of parts represents an ideal situation where separate parts are combined into a single part unless, as each part is added to the assembly, one of the following criteria is met:

1. During the normal operating mode of the product, the part moves relative to all other parts already assembled. (Small motions do not qualify if they can be obtained through the use of elastic hinges.)

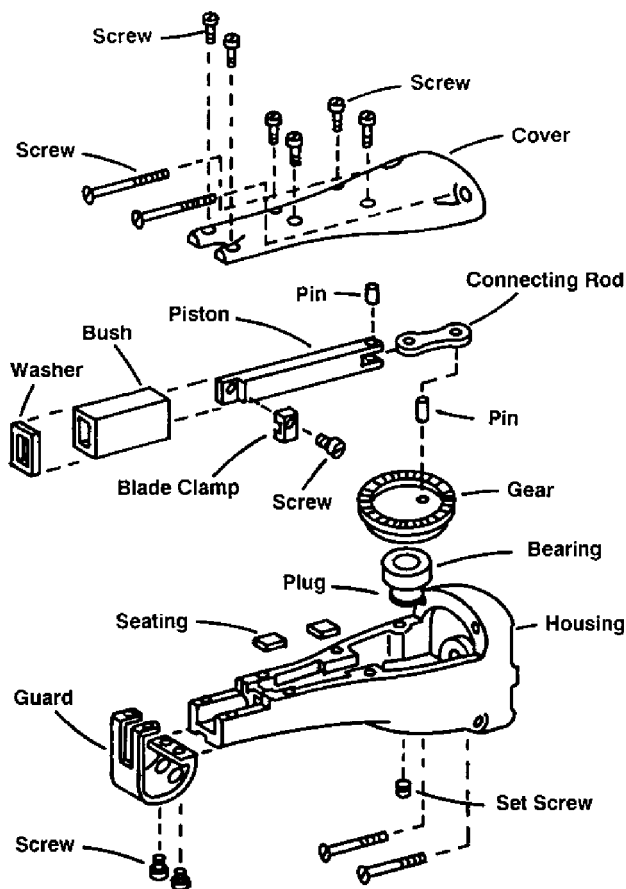

FIG. 3.14 Power saw (new design—29 parts, 2.58 min assembly time). (After Ref. 14.)

2. The part must be of a different material than, or must be isolated from, all other parts assembled (for insulation, electrical isolation, vibration damping, etc.).
3. The part must be separate from all other assembled parts; otherwise the assembly of parts meeting one of the preceding criteria would be prevented.

It should be pointed out that these criteria are to be applied without taking into account general design or service requirements. For example, separate fasteners will not generally meet any of the preceding criteria and should always be considered for elimination. To be more specific, the designer considering the

design of an automobile engine may feel that the bolts holding the cylinder head onto the engine block are necessary separate parts. However, they could be eliminated by combining the cylinder head with the block—an approach that has proved practical in certain circumstances.

If applied properly, these criteria require the designer to consider means whereby the product can be simplified, and it is through this process that enormous improvements in assemblability and manufacturing costs are often achieved. However, it is also necessary to be able to quantify the effects of changes in design schemes. For this purpose the DFA method incorporates a system for estimating assembly cost which, together with estimates of parts cost, will give the designer the information needed to make appropriate trade-off decisions.

3.5 CLASSIFICATION SYSTEMS

The classification system for assembly processes is a systematic arrangement of part features that affect acquisition, movement, orientation, insertion, and fastening of the part together with some operations that are not associated with specific parts such as turning the assembly over.

Selected portions of the complete classification system, its associated definitions, and the corresponding time standards are presented in tables in Figs. 3.15 to 3.17. It can be seen that the classification numbers consist of two digits; the first digit identifies the row and the second digit identifies the column in the table.

The portion of the classification system for manual insertion and fastening processes is concerned with the interaction between mating parts as they are assembled. Manual insertion and fastening consists of a finite variety of basic assembly tasks (peg-in-hole, screw, weld, rivet, press-fit, etc.) that are common to most manufactured products.

It can be seen that for each two-digit code number, an average time is given. Thus, we have a set of time standards that can be used to estimate manual assembly times. These time standards were obtained from numerous experiments, some of which will now be described.

3.6 EFFECT OF PART SYMMETRY ON HANDLING TIME

One of the principal geometrical design features that affects the times required to grasp and orient a part is its symmetry. Assembly operations always involve at least two component parts: the part to be inserted and the part or assembly (receptacle) into which the part is inserted [15]. Orientation involves the proper alignment of the part to be inserted relative to the corresponding receptacle and can always be divided into two distinct operations: (1) alignment of the axis of the

for parts that can be grasped and manipulated with one hand without the aid of grasping tools

sym (deg) = (alpha+ beta)		no handling difficulties			part nests or tangles		
		thickness > 2mm		< 2mm	thickness > 2mm		< 2mm
		size > 15mm	6mm < size < 15mm	size > 6mm	size > 15mm	6mm < size < 15mm	size > 6mm
		0	1	2	3	4	5
sym < 360	0	1.13	1.43	1.69	1.84	2.17	2.45
360 <= sym < 540	1	1.5	1.8	2.06	2.25	2.57	3.0
540 <= sym < 720	2	1.8	2.1	2.36	2.57	2.9	3.18
sym = 720	3	1.95	2.25	2.51	2.73	3.06	3.34

for parts that can be lifted with one hand but require two hands because they severely nest or tangle, are flexible or require forming etc.

	alpha <= 180		alpha = 360
	size > 15mm	6mm < size < 15mm	size > 6mm
	0	1	2
4	4.1	4.5	5.6

FIG. 3.15 Selected manual handling time standards, seconds (parts are within easy reach, are no smaller than 6mm, do not stick together, and are not fragile or sharp). (Copyright 1999 Boothroyd Dewhurst, Inc.)

part that corresponds to the axis of insertion, and (2) rotation of the part about this axis.

It is therefore convenient to define two kinds of symmetry for a part:

1. *Alpha symmetry*: depends on the angle through which a part must be rotated about an axis perpendicular to the axis of insertion to repeat its orientation.

part inserted but not secured immediately or secured by snap fit

		secured by separate operation or part				secured on	
		no holding down required		holding down required		insertion by snap fit	
		easy to align	not easy to align	easy to align	not easy to align	easy to align	not easy to align
		0	1	2	3	4	5
no access or vision difficulties	0	1.5	3.0	2.6	5.2	1.8	3.3
obstructed access or restricted vision	1	3.7	5.2	4.8	7.4	4.0	5.5
obstructed access and restricted vision	2	5.9	7.4	7.0	9.6	7.7	7.7

part inserted and secured immediately by screw fastening with power tool

(times are for 5 revs or less and do not include a tool acquisition time of 2.9s)

		easy to align	not easy to align
		0	1
no access or vision difficulties	3	3.6	5.3
restricted vision only	4	6.3	8.0
obstructed access only	5	9.0	10.7

FIG. 3.16 Selected manual insertion time standards, seconds (parts are small and there is no resistance to insertion). (Copyright 1999 Boothroyd Dewhurst, Inc.)

2. *Beta symmetry*: depends on the angle through which a part must be rotated about the axis of insertion to repeat its orientation.

For example, a plain square prism that is to be inserted into a square hole would first have to be rotated about an axis perpendicular to the insertion axis. Since, with such a rotation, the prism will repeat its orientation every 180°, it can be

	screw tighten with power tool	manipulation, reorientation or adjustment	addition of non solids
	0	1	2
6	5.2	4.5	7

FIG. 3.17 Selected separate operation times, seconds (solid parts already in place). (Copyright 1999 Boothroyd Dewhurst, Inc.)

Definitions:

For Fig. 3.15

Alpha is the rotational symmetry of a part about an axis perpendicular to its axis of insertion. For parts with one axis of insertion, end-to-end orientation is necessary when alpha equals 360 degrees, otherwise alpha equals 180 degrees.

Beta is the rotational symmetry of a part about its axis of insertion. The magnitude of rotational symmetry is the smallest angle through which the part can be rotated and repeat its orientation. For a cylinder inserted into a circular hole, beta equals zero.

Thickness is the length of the shortest side of the smallest rectangular prism that encloses the part. However, if the part is cylindrical, or has a regular polygonal cross-section with five or more sides, and the diameter is less than the length, then thickness is defined as the radius of the smallest cylinder which can enclose the part.

Size is the length of the longest side of the smallest rectangular prism that can enclose the part.

For Fig. 3.16

Holding down required means that the part will require gripping, realignment, or holding down before it is finally secured.

Easy to align and position means that insertion is facilitated by well designed chamfers or similar features.

Obstructed access means that the space available for the assembly operation causes a significant increase in the assembly time.

Restricted vision means that the operator has to rely mainly on tactile sensing during the assembly process.

termed 180° alpha symmetry. The square prism would then have to be rotated about the axis of insertion, and since the orientation of the prism about this axis would repeat every 90°, this implies a 90° beta symmetry. However, if the square prism were to be inserted in a circular hole, it would have 180° alpha symmetry

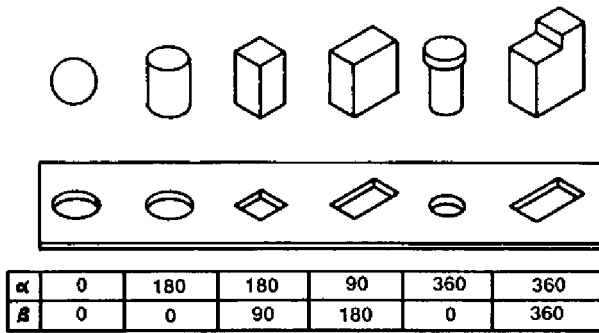

FIG. 3.18 Alpha and beta rotational symmetries for various parts.

and 0° beta symmetry. Figure 3.18 gives examples of the symmetry of simple-shaped parts.

A variety of predetermined time standard systems are presently used to establish assembly times in industry. In the development of these systems, several different approaches have been employed to determine relationships between the amount of rotation required to orient a part and the time required to perform that rotation. Two of the most commonly used systems are the methods time measurement (MTM) and work factor (WF) systems.

In the MTM system, the “maximum possible orientation” is employed, which is one-half the beta rotational symmetry of a part defined above [16]. The effect of alpha symmetry is not considered in this system. For practical purposes, the MTM system classifies the maximum possible orientation into three groups, namely, (1) symmetric, (2) semisymmetric, and (3) nonsymmetric [3]. Again, these terms refer only to the beta symmetry of a part.

In the WF system, the symmetry of a part is classified by the ratio of the number of ways the part can be inserted to the number of ways the part can be grasped preparatory to insertion [17]. In the example of a square prism to be inserted into a square hole, one particular end first, it can be inserted in four ways out of the eight ways it could be suitably grasped. Hence, on the average, one-half of the parts grasped would require orientation, and this is defined in the WF system as a situation requiring 50% orientation [17]. Thus, in this system, account is taken of alpha symmetry, and some account is taken of beta symmetry. Unfortunately, these effects are combined in such a way that the classification can only be applied to a limited range of part shapes.

Numerous attempts were made to find a single parameter that would give a satisfactory relation between the symmetry of a part and the time required for orientation. It was found that the simplest and most useful parameter was the sum

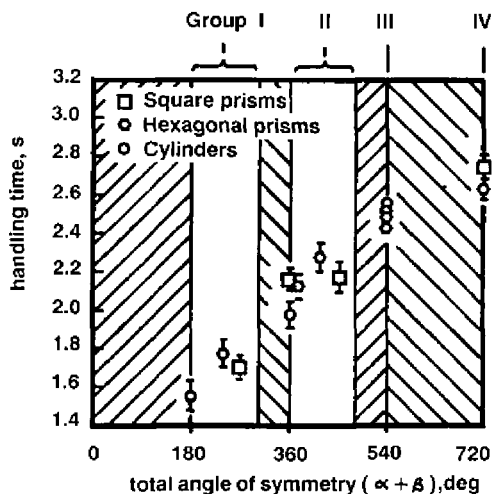

FIG. 3.19 Effect of symmetry on the time required for part handling. Times are average for two individuals and shaded areas represent nonexistent values of the total angle of symmetry.

of the alpha and beta symmetries [5]. This parameter, which will be termed the total angle of symmetry, is therefore given by

$$\text{Total angle of symmetry} = \alpha + \beta \quad (3.2)$$

The effect of the total angle of symmetry on the time required to handle (grasp, move, orient, and place) a part is shown in Fig. 3.19. In addition, the shaded areas indicate the values of the total angle of symmetry that cannot exist. It is evident from these results that the symmetry of a part can be conveniently classified into five groups. However, the first group, which represents a sphere, is not generally of practical interest; therefore, four groups are suggested that are employed in the coding system for part handling (Fig. 3.15). Comparison of these experimental results with the MTM and WF orientation parameters showed that these parameters do not account properly for the symmetry of a part [5].

3.7 EFFECT OF PART THICKNESS AND SIZE ON HANDLING TIME

Two other major factors that affect the time required for handling during manual assembly are the thickness and the size of the part. The thickness and size of a part are defined in a convenient way in the WF system, and these definitions have

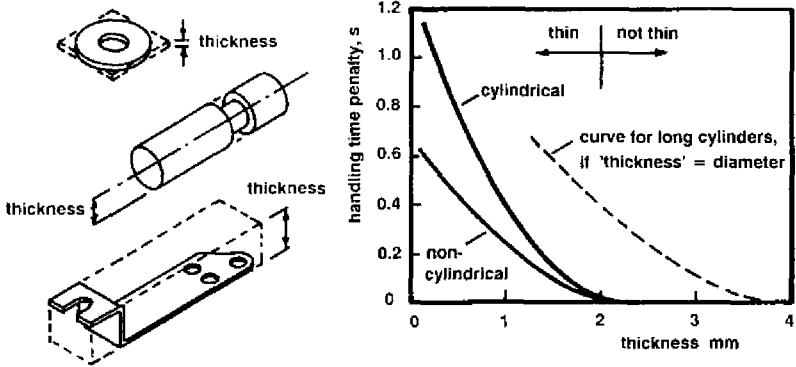

FIG. 3.20 Effect of part thickness on handling time.

been adopted for the DFA method. The thickness of a “cylindrical” part is defined as its radius, whereas for noncylindrical parts the thickness is defined as the maximum height of the part with its smallest dimension extending from a flat surface (Fig. 3.20). Cylindrical parts are defined as parts having cylindrical or other regular cross sections with five or more sides. When the diameter of such a part is greater than or equal to its length, the part is treated as noncylindrical. The reason for this distinction between cylindrical and noncylindrical parts when defining thickness is illustrated by the experimental curves shown in Fig. 3.20. It can be seen that parts with a “thickness” greater than 2 mm present no grasping or handling problems. However, for long cylindrical parts this critical value would have occurred at a value of 4 mm if the diameter had been used for the “thickness”. Intuitively, we see that grasping a long cylinder 4 mm in diameter is equivalent to grasping a rectangular part 2 mm thick if each is placed on a flat surface.

The size (also called the major dimension) of a part is defined as the largest nondiagonal dimension of the part’s outline when projected on a flat surface. It is normally the length of the part. The effects of part size on handling time are shown in Fig. 3.21. Parts can be divided into four size categories as illustrated. Large parts involve little or no variation in handling time with changes in their size; the handling time for medium and small parts displays progressively greater sensitivity with respect to part size. Since the time penalty involved in handling very small parts is large and very sensitive to decreasing part size, tweezers will usually be required to manipulate such parts. In general, tweezers can be assumed to be necessary when size is less than 2 mm.

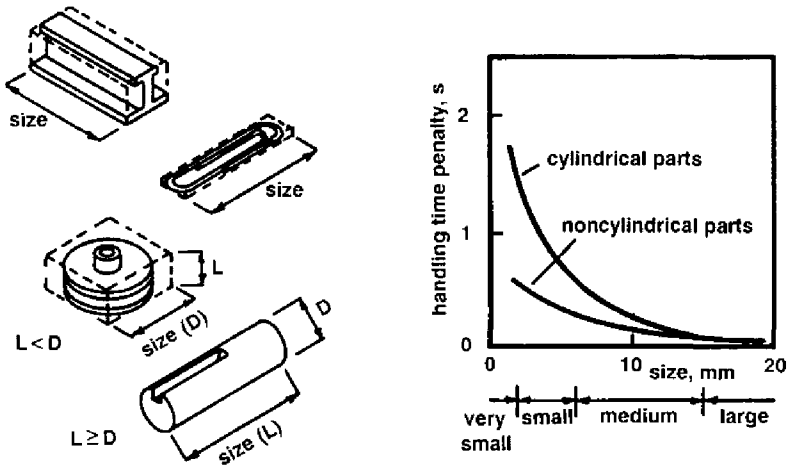

FIG. 3.21 Effect of part size on handling time.

3.8 EFFECT OF WEIGHT ON HANDLING TIME

Work has been carried out [18] on the effects of weight on the grasping, controlling, and moving of parts. The effect of increasing weight on grasping and controlling is found to be an additive time penalty and the effect on moving is found to be a proportional increase of the basic time. For the effect of weight on a part handled using one hand, the total adjustment t_{pw} to handling time can be represented by the following equation [3]:

$$t_{pw} = 0.0125W + 0.011Wt_h \quad (3.3)$$

where W (lb) is the weight of the part and t_h (s) is the basic time for handling a "light" part when no orientation is needed and when it is to be moved a short distance. An average value for t_h is 1.13, and therefore the total time penalty due to weight would be approximately $0.025W$.

If we assume that the maximum weight of a part to be handled using one hand is around 10–20 lb, the maximum penalty for weight is 0.25–0.5 s and is a fairly small correction. It should be noted, however, that Eq. (3.3) does not take into account the fact that larger parts will usually be moved greater distances, resulting in more significant time penalties. These factors will be discussed later.

3.9 PARTS REQUIRING TWO HANDS FOR MANIPULATION

A part may require two hands for manipulation when:

The part is heavy.

Very precise or careful handling is required.

The part is large or flexible.

The part does not possess holding features, thus making one-hand grasp difficult.

Under these circumstances, a penalty is applied because the second hand could be engaged in another operation—perhaps grasping another part. Experience shows that a penalty factor of 1.5 should be applied in these cases.

3.10 EFFECTS OF COMBINATIONS OF FACTORS

In the previous sections, various factors that affect manual handling times have been considered. However, it is important to realize that the penalties associated with each individual factor are not necessarily additive. For example, if a part requires additional time to move it from A to B, it can probably be oriented during the move. Therefore, it may be wrong to add the extra time for part size and an extra time for orientation to the basic handling time. The following gives some examples of results obtained when multiple factors are present.

3.11 EFFECT OF SYMMETRY FOR PARTS THAT SEVERELY NEST OR TANGLE AND MAY REQUIRE TWEEZERS FOR GRASPING AND MANIPULATION

A part may require tweezers when (Fig. 3.22):

Its thickness is so small that finger-grasp is difficult.

Vision is obscured and repositioning is difficult because of its small size.

Touching it is undesirable, because of high temperature, for example.

Fingers cannot access the desired location.

A part is considered to nest or tangle severely when an additional handling time of 1.5 s or greater is required due to these factors. In general, two hands will be required to separate severely nested or tangled parts. Helical springs with open ends and widely spaced coils are examples of parts that severely nest or tangle. Figure 3.23 shows how the time required for orientation is affected by the alpha and beta angles of symmetry for parts that nest or tangle severely and may require tweezers for handling.

In general, orientation using hands results in a smaller time penalty than orientation using tweezers, therefore factors necessitating the use of tweezers should be avoided if possible.



thickness so small
that finger grasp
is difficult



vision is obscured and pre-positioning
is difficult because of small size

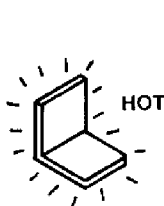

undesirable to touch the part



fingers cannot
access desired
location

FIG. 3.22 Examples of parts that may require tweezers for handling.

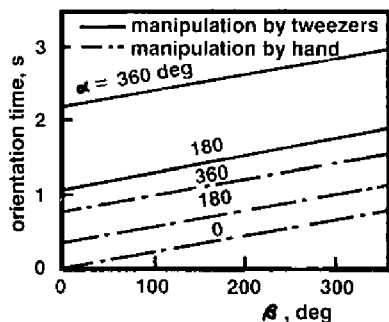
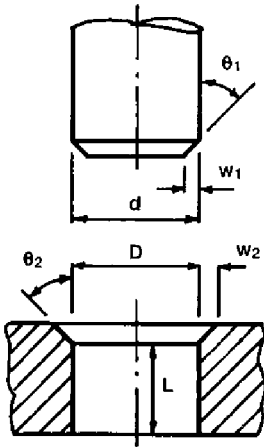

FIG. 3.23 Effect of symmetry on handling time when parts nest or tangle severely. (Disentangling time is not included.)

3.12 EFFECT OF CHAMFER DESIGN ON INSERTION OPERATIONS

Two common assembly operations are the insertion of a peg (or shaft) into a hole and the placement of a part with a hole onto a peg. The geometries of traditional conical chamfer designs are shown in Fig. 3.24. In Fig. 3.24a, which shows the

(a) Geometry of Peg



(b) Geometry of Hole

FIG. 3.24 Geometries of peg and hole.

design of a chamfered peg, d is the diameter of the peg, w_1 is the width of the chamfer, and θ_1 is the semiconical angle of the chamfer. In Fig. 3.24b, which shows the design of a chamfered hole, D is the diameter of the hole, w_2 is the width of the chamfer, and θ_2 is the semiconical angle of the chamfer. The dimensionless diametral clearance c between the peg and the hole is defined by

$$(D - d)/D \quad (3.4)$$

A typical set of results [9] showing the effects of various chamfer designs on the time taken to insert a peg in a hole are presented in Fig. 3.25. From these and other results, the following conclusions have been drawn:

1. For a given clearance, the difference in the insertion time for two different chamfer designs is always a constant.
2. A chamfer on the peg is more effective in reducing insertion time than the same chamfer on the hole.
3. The maximum width of the chamfer that is effective in reducing the insertion time for both the peg and the hole is approximately $0.1D$.
4. For conical chamfers, the most effective design provides chamfers on both the peg and the hole, with $w_1 = w_2 = 0.1D$ and $\theta_1 = \theta_2 < 45$.
5. The manual insertion time is not sensitive to variations in the angle of the chamfer for the range $10 < \theta < 50$.

6. A radiused or curved chamfer can have advantages over a conical chamfer for small clearances.

It was learned from the peg insertion experiments [9] that the long manual insertion time for the peg and hole with a small clearance is probably due to the type of engagement occurring between the peg and the hole during the initial stages of insertion. Figure 3.26 shows two possible situations that will cause difficulties. In Fig. 3.26a, the two points of contact arising on the same circular cross section of the peg give rise to forces resisting the insertion. In Fig. 3.26b, the peg has become jammed at the entrance of the hole. An analysis was carried out to find a geometry that would avoid these unwanted situations. It showed that a chamfer conforming to a body of constant width (Fig. 3.27) is one of the designs having the desired properties. It was found that for such a chamfer, the insertion time is independent of the dimensionless clearance c in the range $c > 0.001$. Therefore, the curved chamfer is the optimum design for peg-in-hole insertion operations (Fig. 3.25). However, since the manufacturing costs for curved chamfers would normally be greater than for conical chamfers, the modified chamfer would only be worthy of consideration for very small values of clearance when the significant reductions in insertion time might compensate for the higher cost. An interesting example of a curved chamfer is the geometry of a bullet. Its design not only has aerodynamic advantages but is also ideal for ease of insertion.

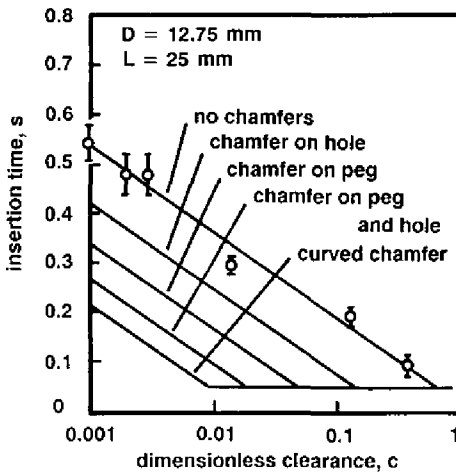

FIG. 3.25 Effect of clearance on insertion time. (After Ref. 9.) (For clarity, experimental results are shown for only one case.)

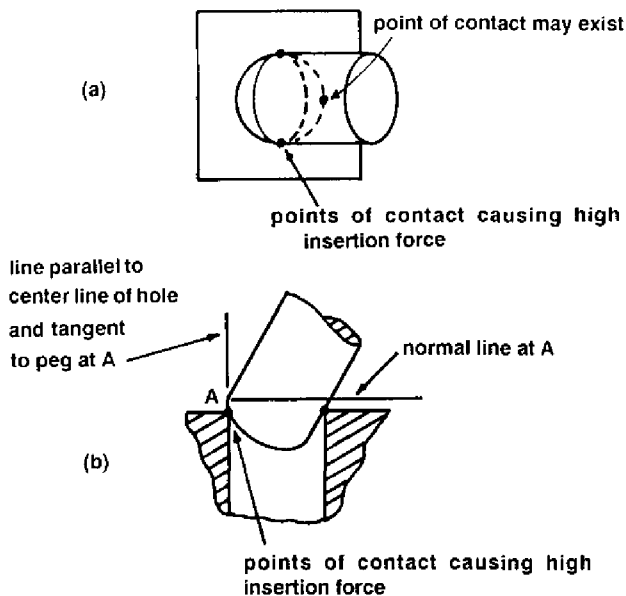

FIG. 3.26 Points of contact on chamfer and hole.

3.13 ESTIMATION OF INSERTION TIME

Empirical equations have been derived [9] to estimate the manual insertion time t_i for both conical chamfers and curved chamfers. For conical chamfers (Fig. 3.24), where the width of 45° chamfers is $0.1d$, the manual insertion time for a plain cylindrical peg t_i is given by

$$t_i = -70 \ln c + f(\text{chamfers}) + 3.7L + 0.75d \text{ ms} \quad (3.5)$$

or

$$t_i = 1.4L + 15 \text{ ms} \quad (3.6)$$

whichever is larger, and where

$$\begin{aligned}
 f(\text{chamfers}) &= -100 \text{ (no chamfer)} \\
 &= -220 \text{ (chamfer on hole)} \\
 &= -250 \text{ (chamfer on peg)} \\
 &= -370 \text{ (chamfer on peg and hole)}
 \end{aligned} \quad (3.7)$$

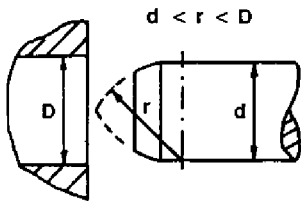

FIG. 3.27 Chamfer of constant width.

For modified curved chamfers (Fig. 3.27) the insertion time is given by

$$t_i = 1.4L + 15 \quad (3.8)$$

Example: $D = 20$ mm, $d = 19.5$ mm, and $L = 75$ mm. There are chamfers on both peg and hole. From Eq. (3.4):

$$c = (20 - 19.5)/20 = 0.025$$

From Eq. (3.5):

$$\begin{aligned} t_i &= -70 \ln(0.025) - 370 + 3.7(75) + 0.75(19.5) \\ &= 181 \text{ ms} \end{aligned}$$

From Eq. (3.6):

$$t_i = 120 \text{ ms}$$

3.14 AVOIDING JAMS DURING ASSEMBLY

Parts with holes that must be assembled onto a peg can easily jam if they are not dimensioned carefully. This problem is typical of assembling a washer on a bolt. In analyzing a part assembled on a peg [7] the hole diameter can be taken to be one unit; all other length dimensions are then measured relative to this unit and are dimensionless (Fig. 3.28). The peg diameter is $1 - c$, where c is the dimensionless diametral clearance between the two mating parts. The resultant force applied to the part during the assembly operation is denoted by P . The line of action of P intercepts the x axis at e , 0. If the following equation is satisfied, the part will slide freely down the peg:

$$P \cos \theta > \mu(N_1 + N_2) \quad (3.9)$$

By resolving forces horizontally

$$P \sin \theta + N_2 - N_1 = 0 \quad (3.10)$$

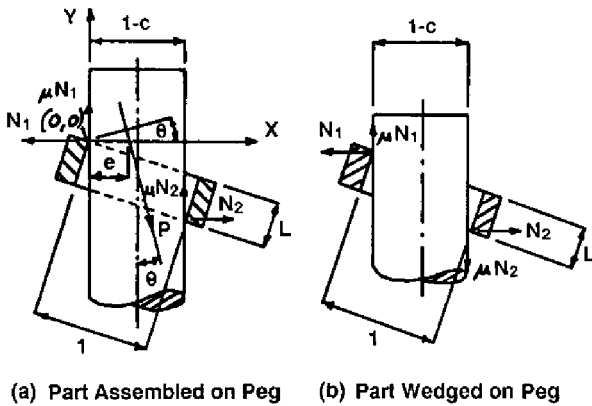

FIG. 3.28 Geometry of part and peg.

and by taking moments about $(0, 0)$

$$\{[1 + L^2 - (1 - c)^2]^{1/2} + \mu(1 - c)\}N_2 - eP \cos \theta = 0 \quad (3.11)$$

From Eqs. (3.9), (3.10), and (3.11):

$$(2\mu e/q - 1) \cos \theta + \mu \sin \theta < 0 \quad (3.12)$$

where

$$q = [1 + L^2 - (1 - c)^2]^{1/2} + \mu(1 - c)$$

Thus, when $e = 0$ and $\cos \theta > 0$, the condition

$$\tan \theta < 1/\mu \quad (3.13)$$

ensures free sliding. If $e = 0$ and $\cos \theta$ is less than 0, then the condition becomes

$$\tan \theta > 1/\mu \quad (3.14)$$

In the case when $\theta = 0$ (the assembly force is applied vertically), Eq. (3.12) yield

$$2\mu e < q \quad (3.15)$$

or

$$e = m(1 - c)/2 \quad (3.16)$$

where m is a positive number. Substituting Eq. (3.16) into Eq. (3.15) gives

$$1 + L^2 > (1 - c)^2[\mu^2(m - 1)^2 + 1] \quad (3.17)$$

When $m = 1$, the force is applied along the axis of the peg. Because $(1 + L^2)$ must always be larger than $(1 - c)^2$, the parts will never jam under these circumstances.

Even if the part jams, a change in the line of action of the force applied will free the part. However, it is also necessary to consider whether the part can be rotated and wedged on the peg. If the net moment of the reaction forces at the contact points is in the direction that rotates the part from the wedged position, then the part will free itself. Thus, for the part to free itself when released:

$$1 + L^2 > (1 - c)^2(\mu^2 + 1) \quad (3.18)$$

Comparing Eq. (3.17) with Eq. (3.18), shows that the condition for the part to wedge without freeing itself occurs when $m = 2$ in Eq. (3.17).

3.15 REDUCING DISC-ASSEMBLY PROBLEMS

When an assembly operation calls for the insertion of a disc-shaped part into a hole, jamming or hang-up is a common problem. Special handling equipment can prevent jams but a simpler, less-costly solution is to analyze all part dimensions carefully before production begins.

Again, the diameter of the hole is one unit; all other dimensions are measured relative to this unit and are dimensionless (Fig. 3.29). The disc diameter is $1 - c$, where c is the dimensionless diametral clearance between the mating parts, P is the resultant force in the assembly operation, and μ is the coefficient of friction. When a disc with no chamfer is inserted into a hole, the condition for free sliding can be determined by

$$L^2 > \mu^2 + 2c - c^2 \quad (3.19)$$

If c is very small, then Eq. (3.19) can be expressed as

$$L > \mu + c/\mu \quad (3.20)$$

If the disc is very thin, that is, if

$$(1 - c)^2 + L^2 < 1 \quad (3.21)$$

the disc can be inserted into the hole by keeping its circular cross section parallel to the wall of the hole and reorienting it when it reaches the bottom of the hole.

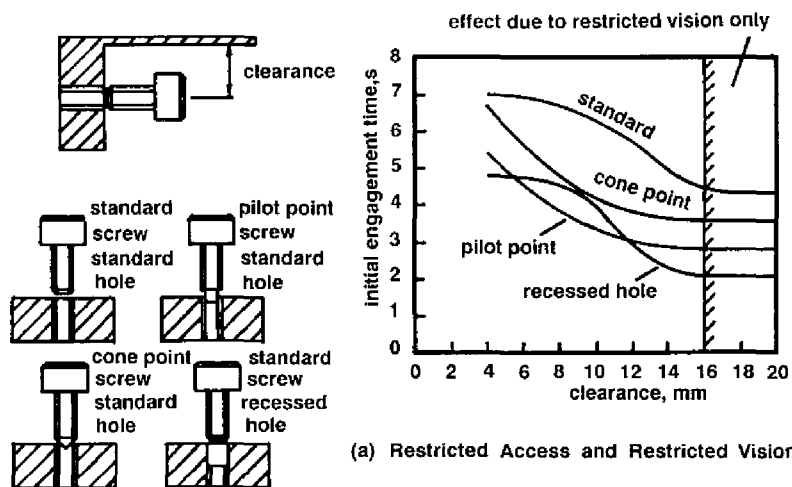

(a) Restricted Access and Restricted Vision

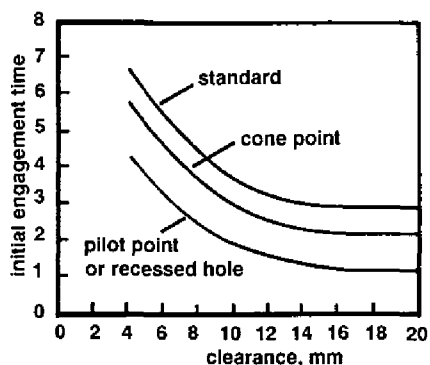

(b) Restricted Access Only

FIG. 3.30 Effects of restricted access and restricted vision on initial engagement of screws.

where the operation of the tools was obstructed to various degrees. It can be seen that the penalties for a box-end wrench are as high as 4 s per revolution when obstructions are present. However, when considering the design of a new product, the designer will not normally consider the type of tool used and can reasonably expect that the best tool for the job will be selected. In the present case this would be either the nut driver or the socket ratchet wrench.

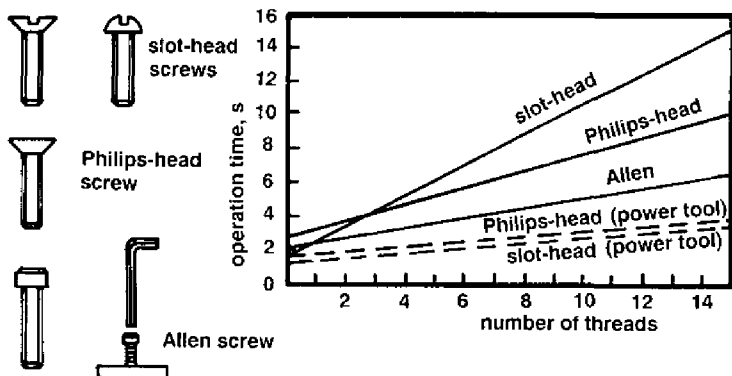

FIG. 3.31 Effect of number of threads on time to pick up the tool, engage the screw, tighten the screw, and replace the tool.

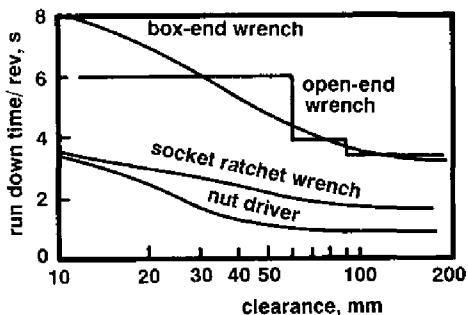
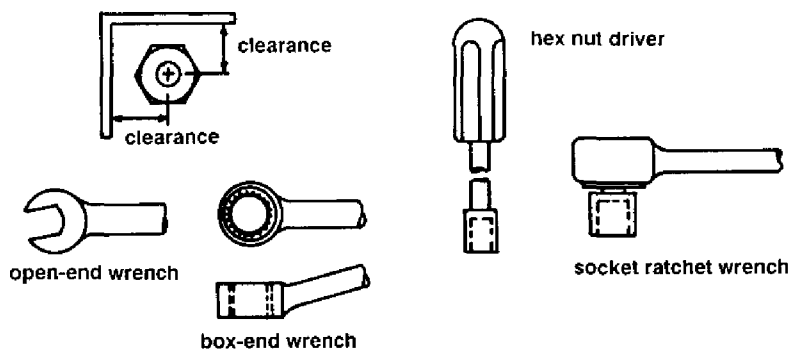

FIG. 3.32 Effect of obstructed access on time to tighten a nut.

3.17 EFFECTS OF OBSTRUCTED ACCESS AND RESTRICTED VISION ON POP-RIVETING OPERATIONS

Figure 3.33 summarizes the results of experiments [10] on the time taken to perform pop-riveting operations. In the experiments, the average time taken to pick up the tool, change the rivet, move the tool to the correct location, insert the rivet and return the tool to its original location was 7.3 s. In Fig. 3.33a the combined effects of obstructed access and restricted vision are summarized, and Fig. 3.33b shows the effects of obstructed access alone. In the latter case, time penalties of up to 1 s can be incurred although, unless the clearances are quite small, the penalties are negligible. With restricted vision present, much higher penalties, on the order of 2 to 3 s, were obtained.

3.18 EFFECTS OF HOLDING DOWN

Holding down is required when parts are unstable after insertion or during subsequent operations. It is defined as a process that, if necessary, it maintains the position and orientation of parts already in place prior to or during subsequent operations. The time taken to insert a peg vertically through holes in two or more stacked parts can be expressed as the sum of a basic time t_b and a time penalty t_p . The basic time is the time to insert the peg when the parts are prealigned and self-locating, as shown in Fig. 3.34a and can be expressed [11] as:

$$t_b = -0.07 \ln c - 0.1 + 3.7L + 0.75d_g \quad (3.22)$$

where

$c = (D - d)/D$ and is the dimensionless clearance ($0.1 \geq c \geq 0.0001$)

L = the insertion depth in meters

d_g = the grip size in meters ($0.1 \text{ m} \geq d_g \geq 0.01 \text{ m}$).

Example: $D = 20 \text{ mm}$, $d = 19.6 \text{ mm}$, $c = (D - d)/D = (20 - 19.6)/20 = 0.02$,
 $L = 100 \text{ mm} = 0.10 \text{ m}$, $d_g = 40 \text{ mm} = 0.04 \text{ m}$ then

$$\begin{aligned} t_b &= -0.07 \ln c - 0.1 + 3.7L + 0.75d_g \\ &= -0.07 \ln 0.02 - 0.1 + 3.7 \times 0.10 + 0.75 \times 0.04 \\ &= 0.27 - 0.1 + 0.37 + 0.03 \\ &= 0.57 \text{ s} \end{aligned}$$

The graphs presented in Figs. 3.34 and 3.35 will allow the time penalty t_p to be determined for three conditions:

When easy-to-align parts have been aligned and require holding down (Fig. 3.34b)

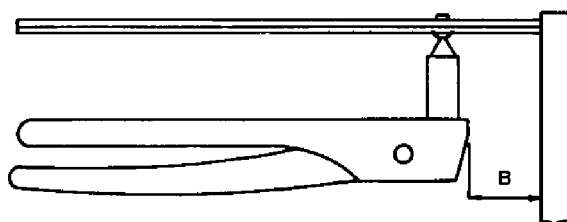

View from above

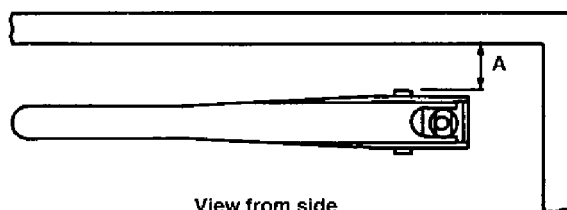

View from side

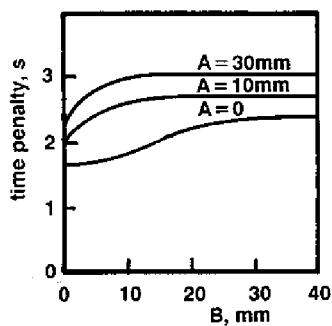

(a) vision restricted

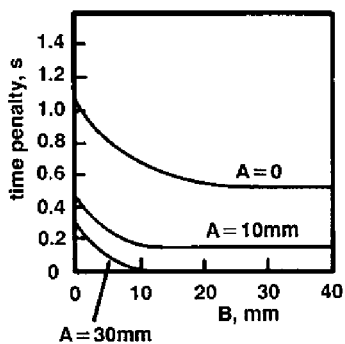

(b) vision unrestricted

FIG. 3.33 Effects of obstructed access and restricted vision on the time to insert a pop rivet. (After Ref. 10.)

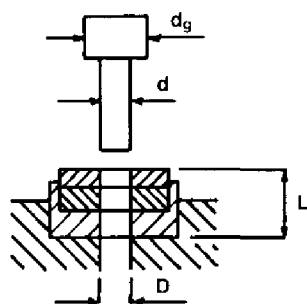

(a)
Parts self-locating
and pre-aligned

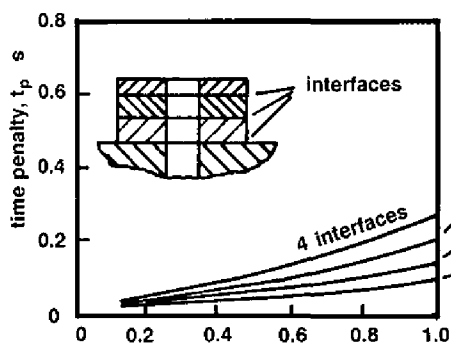

(b)
easy-to-align
parts

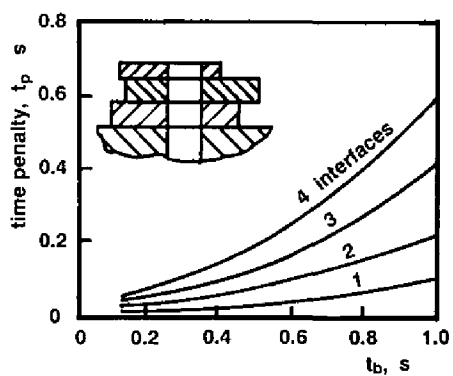

(c)
not
easy-to-align
parts

FIG. 3.34 Effects of holding down on insertion time. (After Ref. 11.)

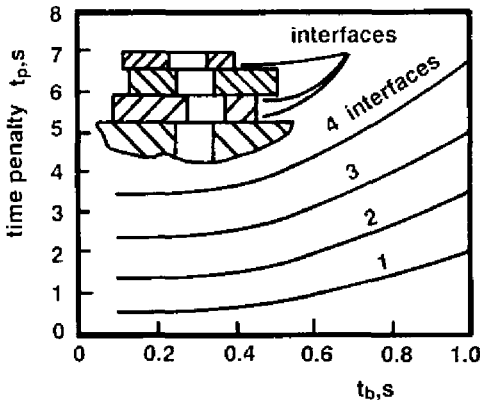

FIG. 3.35 Effects of holding down and realignment on insertion time for difficult-to-align parts. (After Ref. 11.)

When difficult-to-align parts have been aligned and require holding down (Fig. 3.34c)

When difficult-to-align parts require alignment and holding down (Fig. 3.35).

For the example given above where $t_b = 0.57$ s, the time penalty $t_p = 0.1$ s for the conditions of Fig. 3.34b, the time penalty $t_p = 0.15$ s for the conditions of Fig. 3.34c, and $t_p = 3$ s for the conditions of Fig. 3.35.

3.19 MANUAL ASSEMBLY DATABASE AND DESIGN DATA SHEETS

The preceding sections have presented a selection of the results of some of the analyses and experiments conducted during the development of the DFA method. For the development of the classification schemes and time standards presented earlier it was necessary to obtain an estimate of the average time, in seconds, to complete the operation for all the parts falling within each classification or category. For example, the uppermost left-hand box in Fig. 3.15 (code 00) gives 1.13 for the average time to grasp, orient, and move a part

- That can be grasped and manipulated with one hand
- Has a total symmetry angle of less than 360° (a plain cylinder, for example)
- Is larger than 15 mm
- Has a thickness greater than 2 mm
- Has no handling difficulties, such as flexibility, tendency to tangle or nest, etc.

Clearly, a wide range of parts will fall within this category and their handling times will vary somewhat. The figure presented is only an average time for the range of parts.

To illustrate the type of problem that can arise through the use of the group technology coding or classification scheme employed in the DFA method, we can consider the assembly of a part having a thickness of 1.9 mm. We shall assume that, except for its thickness of less than 2 mm, the part would be classified as code 00 (Fig. 3.15). However, because of the part's thickness, the appropriate code would be 02 and the estimated handling time would be 1.69 instead of 1.13 s, representing a time penalty of 0.56 s. Turning now to the results of experiments for the effect of thickness (Fig. 3.20), it can be seen that for a cylindrical part the actual time penalty is on the order of only 0.01 to 0.02 s. We would therefore expect an error in our results of about 50%. Under normal circumstances, experience has shown that these errors tend to cancel—with some parts the error results in an overestimate of time and with some an underestimate. However, if an assembly contains a large number of identical parts, care must be taken to check whether the part characteristics fall close to the limits of the classification; if they do, then the detailed results presented above should be consulted.

3.20 APPLICATION OF THE DFA METHODOLOGY

To illustrate how DFA is applied in practice, we shall consider the controller assembly shown in Fig. 3.36. The assembly of this product first involves securing a series of assemblies to the metal frame using screws, connecting these assemblies together in various ways and then securing the resulting assembly into the plastic cover, again using screws. An undesirable feature of the design of the plastic cover is that the small subassemblies must be fastened to the metal frame before the metal frame can be secured to the plastic cover.

Figure 3.37 shows a completed worksheet analysis for the controller in the form of a tabulated list of operations and the corresponding assembly times and costs. Each assembly operation is divided into handling and insertion, and the corresponding times and two-digit code numbers for each process are given. Assembly starts by placing the pressure regulator (a purchased item) upside-down into a fixture. The metal frame is placed onto the projecting spindle of the pressure regulator and secured with the nut. The resulting assembly is then turned over in the fixture to allow for the addition of other items to the metal frame.

Next the sensor and the strap are placed and held in position while two screws are installed. Clearly, the holding of these two parts and the difficulty of the screw insertions will impose time penalties on the assembly process.

After tape is applied to the thread on the sensor, the adaptor nut can be screwed into place. Then one end of the tube assembly is screwed to the threaded

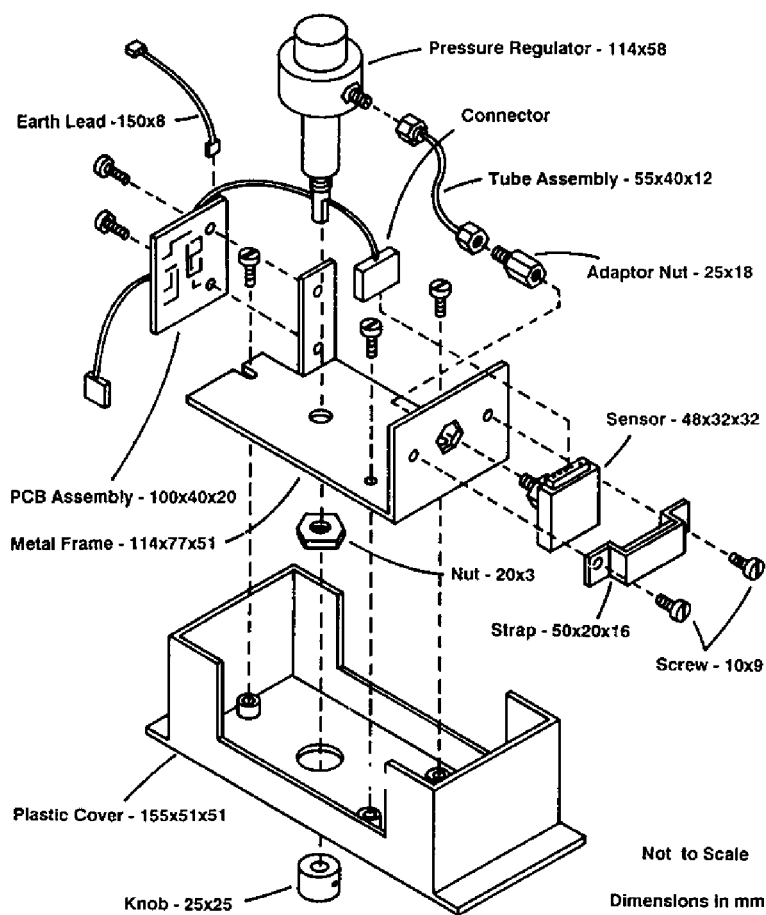

FIG. 3.36 Controller assembly.

extension on the pressure regulator and the other end to the adaptor nut. Clearly, both of these are difficult and time-consuming operations.

The printed circuit board (PCB) assembly is now positioned and held in place while two screws are installed, after which its connector is snapped into the sensor and the earth lead is snapped into place.

The whole assembly must be turned over once again to allow for the positioning and holding of the knob assembly while the screw-fastening operation can be carried out. Finally, the plastic cover is placed in position and the entire

	No. of items RP	Tool acquire time TA	Hand-ling code	Hand-ling time TH	Insert-ion code	Insert-ion time TI	Total time TA+RP* (TH+TI)	Mini-mum part count	
1. Pressure regulator	1	-	30	1.95	00	1.5	3.45	1	Place in fixture
2. Metal frame	1	-	30	1.95	02	2.6	4.55	1	Add
3. Nut	1	2.9	00	1.13	31	5.3	9.33	0	Add and screw fasten
4. Reorientation	1	-	-	-	61	4.5	4.50	-	Reorient and adjust
5. Sensor	1	-	30	1.95	03	5.2	7.15	1	Add
6. Strap	1	-	20	1.80	03	5.2	7.00	0	Add and hold down
7. Screw	2	2.9	11	1.80	31	5.3	17.10	0	Add and screw fasten
8. Apply tape	1	-	-	-	62	7.0	7.00	-	Special operation
9. Adapter nut	1	2.9	10	1.50	51	10.7	15.10	0	Add and screw fasten
10. Tube assembly	1	-	42	5.60	10	3.7	9.30	0	Add and screw fasten
11. Screw fastening	1	2.9	-	-	60	5.2	8.10	-	Standard operation
12. PCB assembly	1	-	42	5.60	03	5.2	10.80	1	Add and hold down
13. Screw	2	2.9	11	1.80	31	5.3	17.10	0	Add and screw fasten
14. Connector	1	-	30	1.95	05	3.3	5.25	0	Add and snap fit
15. Earth lead	1	-	42	5.60	05	3.3	8.90	0	Add and snap fit
16. Reorientation	1	-	-	-	61	4.5	4.50	-	Reorient and adjust
17. Knob assembly	1	-	30	1.95	03	5.2	7.15	1	Add and hold down
18. Screw fastening	1	2.9	-	-	60	5.2	8.10	-	Standard operation
19. Plastic cover	1	-	30	1.95	03	5.2	7.15	0	Add and hold down
20. Reorientation	1	-	-	-	61	4.5	4.50	-	Reorient and adjust
21. Screw	3	2.9	11	1.80	51	10.7	40.4	0	Add and screw fasten
							206.43	5	Totals

FIG. 3.37 Completed worksheet analysis for the controller assembly.

assembly is turned over for the third time to allow the three screws to be inserted. It should be noted that access for the insertion of these screws is very restricted.

It is clear from this description of the assembly sequence that many aspects of the design could be improved. However, a step-by-step analysis of each operation is necessary before changes to simplify the product structure and reduce assembly difficulties can be identified and quantified. First we shall look at how the handling and insertion times are established. The addition of the strap will be considered by way of example. This operation is the sixth item on the worksheet and the line of information is completed as follows:

NUMBER OF ITEMS, RP

There is one strap.

HANDLING CODE

The insertion axis for the strap is horizontal in Fig. 3.36 and the strap can only be inserted one way along this axis, so the alpha angle of symmetry is 360° . If the strap is rotated about the axis of insertion, it will repeat its orientation every 180° , which is, therefore, the beta angle of symmetry. Thus, the total angle of symmetry is 540° . Referring to the database for handling time (Fig. 3.15), since the strap can be grasped and manipulated using one hand without the aid of tools and alpha plus beta is 540° , the first digit of the handling code is 2. The strap presents no handling difficulties (can be grasped and separated from bulk easily), its thickness

is greater than 2 mm, and its size is greater than 15 mm; therefore, the second digit is 0 giving a handling code of 20.

HANDLING TIME PER ITEM, TH

A handling time of 1.8 s corresponds to a handling code of 20 (Fig. 3.15).

INSERTION CODE

The strap is not secured as part of the insertion process and since there is no restriction to access or vision, the first digit of the insertion code is 0 (Fig. 3.16). Holding down is necessary while subsequent operations are carried out, and the strap is not easy to align because no features are provided to facilitate alignment of the screw holes. Therefore, the second digit will be 3, giving an insertion code of 03.

INSERTION TIME PER ITEM, TI

An insertion time of 5.2 s corresponds to an insertion code of 03 (Fig. 3.16).

TOTAL OPERATION TIME

This is the sum of the handling and insertion times multiplied by the number of items plus tool acquisition time if necessary i.e., $TA + RP(TH + TI)$. For the strap the total operation time is therefore 7.0 s.

FIGURES FOR MINIMUM PARTS

As explained earlier, the establishment of a theoretical minimum part count is a powerful way to identify possible simplifications in the product structure. For the strap the three criteria for separate parts are applied after the pressure regulator, the metal frame, the nut, and the sensor have been assembled.

1. The strap does not move relative to these parts and so it could theoretically be combined with any of them.
2. The strap does not have to be of a different material—in fact it could be of the same plastic material as the body of the sensor and therefore take the form of two lugs with holes projecting from the body. At this point in the analysis the designer would probably determine that since the sensor is a purchased stock item, its design could not be changed. However, it is important to ignore these economic considerations at this stage and consider only theoretical possibilities.
3. The strap clearly does not have to be separate from the sensor in order to allow assembly of the sensor, and therefore none of the three criteria are met and the strap becomes a candidate for elimination. For the strap a zero is placed in the column for minimum parts.

3.20.1 Results of the Analysis

Once the analysis is complete for all operations the appropriate columns can be summed. Thus, for the controller, the total number of parts and subassemblies is 19 and there are six additional operations. The total assembly time is 206.43 s, and, for an assembly worker's rate of \$30/hr, the corresponding assembly cost is \$1.72. The theoretical minimum number of parts is five.

A DFA index is now obtained using Eq. (3.1). In this equation t_a is the basic assembly (handling and insertion) time for one part and can be taken as 3 s on average. Thus, the DFA index is

$$5 \times 3/206.43 = 0.07 \text{ or } 7\%$$

The high-cost processes should now be identified—especially those associated with the installation of parts that do not meet any of the criteria for separate parts. From the worksheet results (Fig. 3.37) it can be seen that attention should clearly be paid to combining the plastic cover with the metal frame. This would eliminate the assembly operation for the cover, the three screws, and the reorientation operation—representing a total time saving of 52.05 s—a figure that forms 25% of the total assembly time. Of course, the designer must check that the cost of the combined plastic cover and frame is less than the total cost of the individual items.

A summary of the items that can be identified for elimination or combination and the appropriate assembly time savings are presented in Table 3.1.

TABLE 3.1 Design Changes and Associated Savings

Design change	Items	Time saving (s)
1. Combine plastic cover with frame, eliminate three screws and a reorientation	19, 20, 21	52.05
2. Eliminate strap and two screws (provide snaps in plastic frame to hold sensor if necessary)	6, 7	24.1
3. Eliminate screws holding PCB assembly (provide snaps in plastic frame)	13	17.1
4. Eliminate two reorientations	4, 16	9.0
5. Eliminate tube assembly and two screw fastening operations (screw adaptor nut and sensor direct to the pressure regulator)	10, 11	17.4
6. Eliminate earth lead (not required with plastic frame)	15	8.7
7. Eliminate connector (plug sensor into PCB)	14	5.25

We have now identified design changes that could result in savings of 133.8 s of assembly time, which forms 65% of the total. In addition, several items of hardware would be eliminated, resulting in reduced part costs. Figure 3.38 shows a conceptual redesign of the controller in which all the proposed design changes have been made, and Fig. 3.39 presents the corresponding revised worksheet. The total assembly time is now 77.93 s and the assembly efficiency is increased to 19%—a fairly respectable figure for this type of assembly. Of course, the designer or design team must now consider the technical and economic consequences of the proposed designs.

First there is the effect on the cost of the parts. However, experience shows, and this example would be no exception, that the savings from parts cost reduction would be greater than the savings in assembly costs, which in this case is \$1.07. It should be realized that the documented savings in materials,

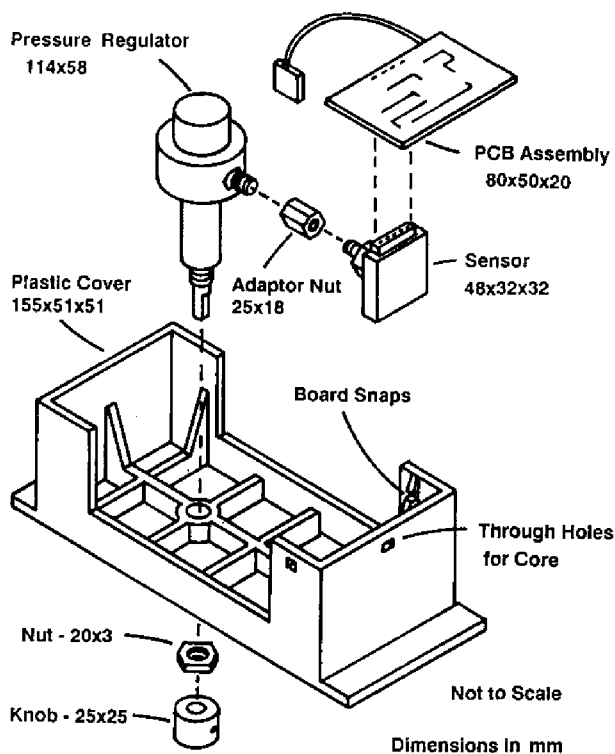

FIG. 3.38 Conceptual redesign of the controller assembly.

	No. of items RP	Tool acquire time TA	Hand-ling code	Hand-ling time TH	Insert-ion code	Insert-ion time TI	Total time TA+RP+TH+TI	Mini-mum part count	
1. Pressure regulator	1	-	30	1.95	00	1.5	3.45	1	Place in fixture
2. Plastic cover	1	-	30	1.95	03	5.2	7.15	1	Add and hold down
3. Nut	1	2.9	00	1.13	31	5.3	9.33	0	Add and screw fasten
4. Knob assembly	1	-	30	1.95	03	5.2	7.15	1	Add and hold down
5. Screw fastening	1	2.9	-	-	60	5.2	8.10	-	Standard operation
6. Reorientation	1	-	-	-	61	4.5	4.50	-	Reorient and adjust
7. Apply tape	1	-	-	-	62	7.0	7.00	-	Special operation
8. Adapter nut	1	2.9	10	1.50	51	10.7	15.10	0	Add and screw fasten
9. Sensor	1	-	30	1.95	31	5.3	7.25	1	Add and screw fasten
10. PCB assembly	1	-	42	5.60	05	3.3	8.9	1	Add and snap fit
							77.93	5	Totals

FIG. 3.39 Completed analysis for the controller assembly redesign.

manufacturing, and assembly represent direct costs. To obtain a true picture, overheads must be added and these can often amount to 200% or more. In addition, there are other savings more difficult to quantify. For example, when a part such as the metal frame is eliminated, all associated documentation—including part drawings—is also eliminated. Also, the part cannot be misassembled or fail in service—factors that lead to improved reliability, maintainability and quality of the product. It is not surprising, therefore, that many U.S. companies have been able to report annual savings measured in millions of dollars as a result of the application of the DFA analysis method described here.

3.21 FURTHER DESIGN GUIDELINES

Some guidelines or design rules for the manual handling and insertion of parts were listed earlier. However, it is possible to identify a few more general guidelines that arise particularly from the application of the minimum parts criteria, many of which found application in the analysis of the controller.

1. *Avoid connections:* If the only purpose of a part or assembly is to connect A to B, then try to locate A and B at the same point. Figure 3.40 illustrates this guideline. Here the two connected assemblies are rearranged to provide increasing assembly and manufacturing efficiency. Also, two practical examples occurred during the analysis of the controller, when it was found that the entire tube assembly could be eliminated and that the wires from the PCB assembly to the connector were not necessary (Fig. 3.36).

2. *Design so that access for assembly operations is not restricted:* Figure 3.41 shows two alternative design concepts for a small assembly. In the first concept the installation of the screws would be very difficult because of the restricted access within the box-shaped base part. In the second concept access is relatively unrestricted because the assembly is built up on the flat base part. An example of

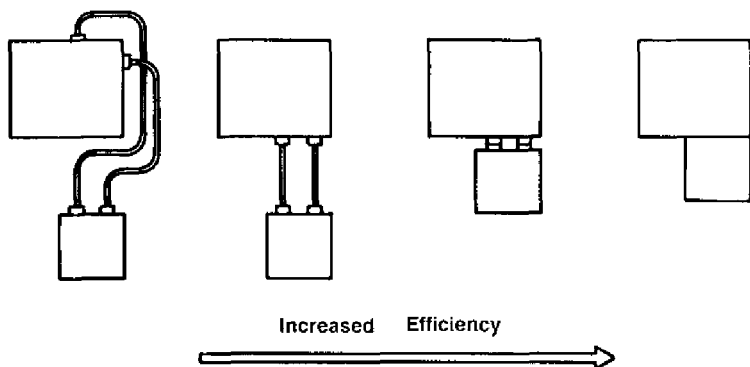

FIG. 3.40 Rearrangement of connected items to improve assembly efficiency and reduce costs.

this type of problem occurred in the controller analysis when the screws securing the metal frame to the plastic cover were installed (item 21—Fig. 3.37).

3. *Avoid adjustments:* Figure 3.42 shows two parts of different materials secured by two screws in such a way that adjustment of the overall length of the assembly is necessary. If the assembly were replaced by one part manufactured

Restricted access for assembly of screws

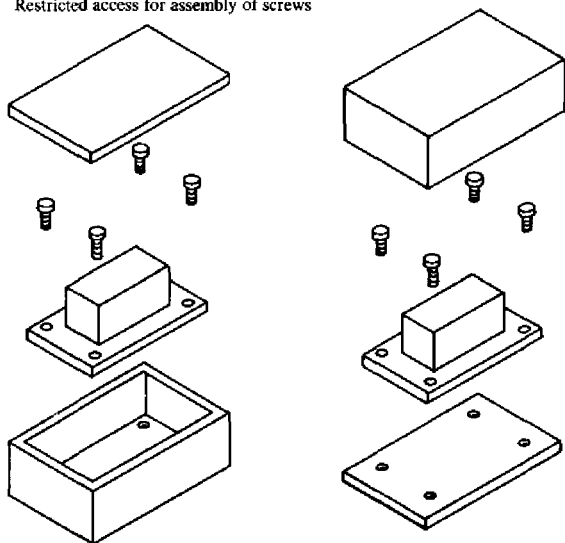

FIG. 3.41 Design concept to provide easier access during assembly.

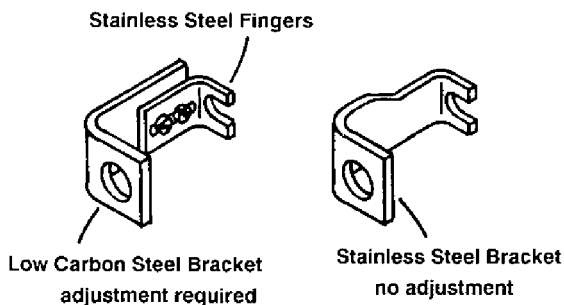

FIG. 3.42 Design to avoid adjustment during assembly.

from the more expensive material, difficult and costly operations would be avoided. These savings would probably more than offset the increase in material costs.

4. *Use kinematic design principles:* There are many ways in which the application of kinematic design principles can reduce manufacturing and assembly cost. Invariably, when located parts are overconstrained, it is necessary either to provide a means of adjustment of the constraining items or to employ more accurate machining operations. Figure 3.43 shows an example where to locate the square block in the plane of the page, six point constraints are used, each one requiring adjustment. According to kinematic design principles only three point constraints are needed together with closing forces. Clearly, the redesign shown in Fig. 3.43 is simpler, requiring fewer parts, fewer assembly operations, and less adjustment. In many circumstances designs where overconstraint is involved result in redundant parts. In the design involving overconstraint in Fig. 3.44 one

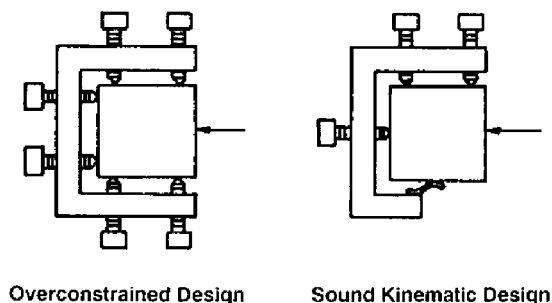

FIG. 3.43 Showing how overconstraint leads to unnecessary complexity in product design.

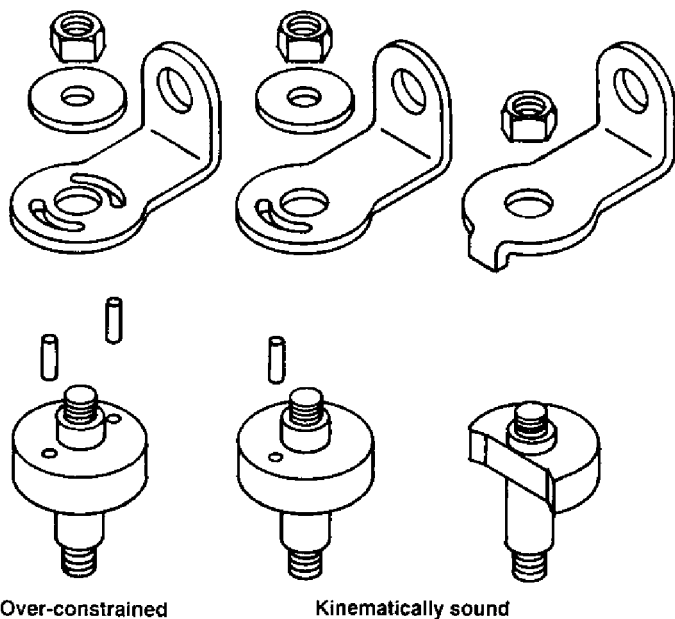

FIG. 3.44 Showing how overconstraint leads to redundancy of parts.

of the pins is redundant. However, application of the minimum parts criteria to the design with a single pin would suggest combining the pin with one of the major parts and combining the washer with the nut.

3.22 LARGE ASSEMBLIES

In the original DFA (design for assembly) method estimates of assembly time were based on a group technology approach in which design features of parts and products were classified into broad categories and, for each category, average handling and insertion times were established. Clearly, for any particular operation, these average times can be considerably higher or lower than the actual times. However, for assemblies containing a significant number of parts, the differences tend to cancel so that the total time will be reasonably accurate. In fact, application of the DFA method in practice has shown that assembly time estimates are reasonably accurate for small assemblies in low-volume production where all the parts are within easy arm reach of the assembly worker.

Clearly, with large assemblies, the acquisition of the individual parts from their storage locations in the assembly area will involve significant additional time. Also, in mass production transfer-line situations, the data for low-volume production will overestimate these times. Obviously, one database of assembly times cannot be accurate for all situations.

Let us take one example. From the DFA databases in Figs. 3.15 to 3.17, the time for acquiring and inserting a standard screw, which is not easy to align, is 8.2 s. This time includes acquisition of the screw, placing it in the assembly manually with a couple of turns, acquiring the power tool, operating the tool, and then replacing it. However, in high-volume production situations, the screws are often automatically fed, and so the time is reduced to about 3.6 s per screw or, for well-designed screws, the time per screw can be less than 2 s.

The DFA method was extended to allow for these possibilities, and more accurate estimates of assembly times are obtained. However, this can reduce the effectiveness of the method. In the preceding example, an analysis using the shorter time for screw insertion would indicate that eliminating screws would not be so advantageous in reducing the assembly time. However, it is known that simplifying the product by combining parts and eliminating separate fasteners has the greatest benefit through reductions in parts cost rather than through reductions in assembly cost; yet the suggestions for these improvements arise from analyses of the assembly of the product. Hence, separate fasteners should, perhaps, be severely penalized even if they take little time to install. In fact, it can be argued that in the preceding example, where screws could be inserted quickly, special equipment was being used to solve problems arising from poor design. This is a good argument for suggesting that early DFA analyses should be carried out assuming that only standard equipment is available. Perhaps later, at the detailed-design stage, attempts can be made to improve the assembly time estimates. Clearly, accurate estimates cannot be made unless detailed descriptions of manufacturing and assembly procedures are available—a situation not present during the early stages of design when the possibilities for cost savings through improved product design are at their greatest. On the other hand, a database of assembly times suitable for small assemblies measuring only a few inches cannot be expected to give even approximate estimates for assemblies containing large parts measuring several feet. It is desirable, therefore, to have databases appropriate to those situations where the size of the product and the production conditions differ significantly. Again, it should be realized that great detail regarding the assembly work area will not generally be available to the designer during the conceptual stages of design.

With these points in mind, the following sections describe an approach to the development of databases that are used to estimate acquisition and insertion times for parts assembled into large products.

3.23 TYPES OF MANUAL ASSEMBLY METHODS

Part acquisition time is highly dependent on the nature of the layout of the assembly area and the method of assembly. For small parts placed within easy reach of the assembly worker, the handling times given in Fig. 3.15 are adequate if bench assembly (Fig. 3.45) or multistation assembly (Fig. 3.46) is employed. It is assumed in both cases that major body motions by the assembly worker are not required.

For volumes that do not justify transfer systems and if the assembly contains several parts that weigh more than about 5 lb or that are over 12 in. in size, it will not be possible to place an adequate supply of parts within easy arm's reach of the assembly worker. In this case, provided the largest part is less than 35 in. in size and no part weighs more than 30 lb, the modular assembly center might be used. This is an arrangement of workbench and storage shelves where the parts are situated as conveniently for the assembly worker as possible (Fig. 3.47). However, because turning, bending, or walking may be necessary for acquisition of some of the parts, the handling times will be increased. It is convenient to identify three modular work centers to accommodate assemblies falling within three size categories where the largest part in the assembly is less than 15 in., from 15 to 25 in., and from 25 to 35 in., respectively.

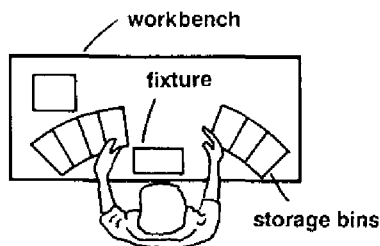

FIG. 3.45 Bench assembly.

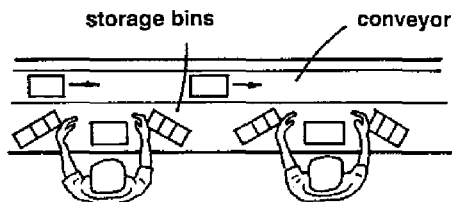

FIG. 3.46 Multistation assembly.

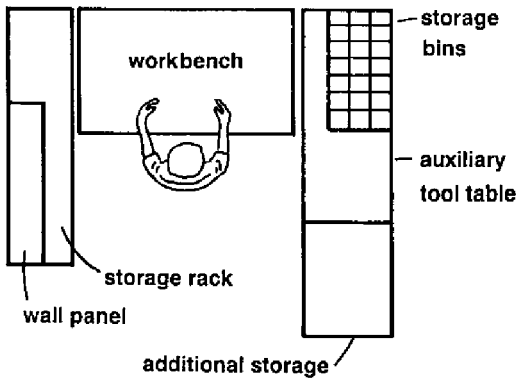

FIG. 3.47 Modular assembly center.

For products with even larger parts, the custom assembly layout can be used. Here the product is assembled on a worktable or on the floor and the various storage shelves and auxiliary equipment are arranged around the periphery of the assembly area (Fig. 3.48). The total working area is larger than that for the modular assembly center and depends on the size category of the largest parts in the assembly. Three subcategories of the custom assembly layout are employed: for assemblies whose largest parts are from 35 to 50 in., from 50 to 65 in., and larger than 65 in.

Also, for large products a more flexible arrangement can be used; this is called the flexible assembly layout. The layout (Fig. 3.49) would be similar in size to the custom assembly layout and the same three subcategories would be employed according to the size of the largest part. However, the use of mobile storage carts and tool carts can make assembly more efficient.

In both the custom assembly layout and the flexible assembly layout, the possibility arises that mechanical assistance in the form of cranes or hand trucks may be needed. In these cases, the working areas may need to be increased in order to accommodate the additional equipment.

For high-volume assembly of products containing large parts (such as in the automobile industry) transfer lines moving past manual assembly stations would be employed (Fig. 3.50).

Two other manual assembly situations exist. The first is assembly of small products with very low volumes—perhaps in a clean room. This would include the assembly of intricate and sensitive devices such as the fuel control valves for an aircraft where instructions must be read for each step and where the worker is near the beginning of the learning curve. The second is where assembly of large products is mainly carried out on site. This type of assembly is usually termed

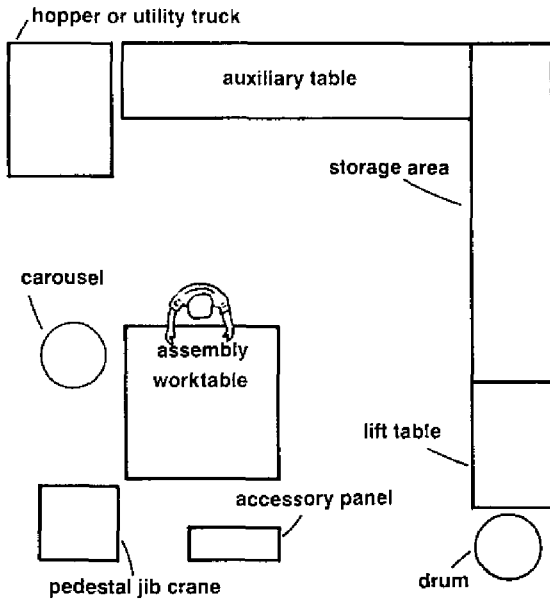

FIG. 3.48 Custom assembly layout.

installation, and an example would be the assembly and installation of a passenger elevator in a multistory building.

In any assembly situation, special equipment may be needed. For example, a positioning device is sometimes needed for positioning and aligning the part—especially prior to welding operations. In these cases, the device must be brought from storage within the assembly area, and then returned after the part has been positioned and perhaps secured. Thus, the total handling time for the device will be roughly twice the handling time for the part and must be taken into account if the volume to be produced is small.

Figure 3.51 summarizes the basic types of manual assembly methods described above. It can be seen that the first three methods assume only small parts are being assembled. In these cases it can be assumed that the parts are all placed close to hand and will be acquired one-at-a-time. Therefore if, say, six screws are to be inserted, there is no advantage in collecting the six screws simultaneously. However, with the assembly of products containing large parts, where small items such as fasteners may not be located within easy reach or where the assembly worker must move to various locations for the small items, there may be considerable advantage in acquiring multiple parts when needed.

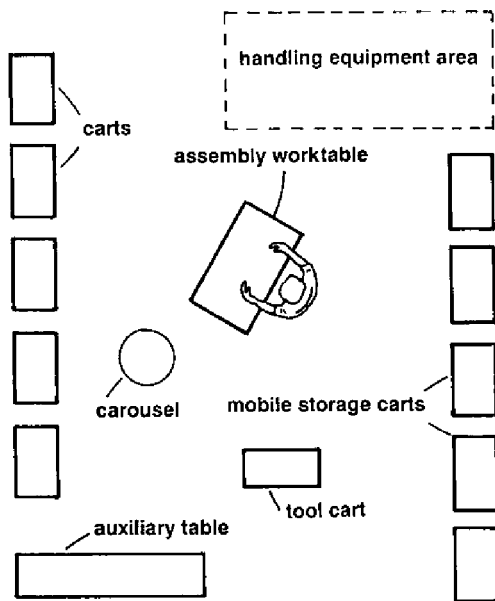

FIG. 3.49 Flexible assembly layout.

3.24 EFFECT OF ASSEMBLY LAYOUT ON ACQUISITION TIMES

For assembly method categories, 4, 5, and 6, Fig. 3.52 presents a summary of the results obtained from a thorough study of typical assembly layouts of various sizes. For each of the nine subcategories described above, a typical layout was designed using standard items such as worktables and storage racks. Then the various sizes and weights of parts were assumed to be stored at the most suitable locations. An example for the custom assembly layout is shown in Fig. 3.53. Using MTM time standards [19], the times for the retrieval of parts within the various size and weight categories were then estimated [20]. Finally, the results were averaged to give the data in Fig. 3.52. In addition, since it was found that the times for the custom assembly and flexible assembly layout were similar, these were combined and averaged. Thus, for example, the basic part retrieval or acquisition time for the mid-sized custom assembly layout or the mid-sized flexible assembly layout (largest part 50 to 65 in.) was determined to be 11.61 s.

For the effect of part weight, a correction factor can be applied, as described in an earlier section. However, the resulting correction is quite small and, therefore, it would seem feasible to divide parts into broad weight categories of, say, 0 to

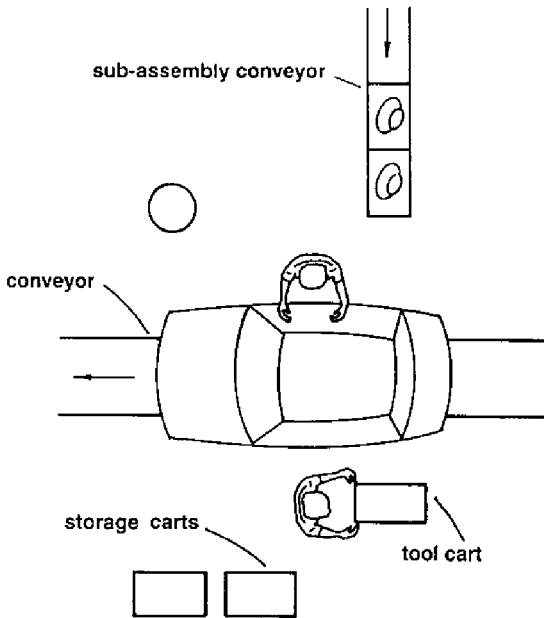

FIG. 3.50 Multistation assembly of large products.

30 lb and over 30 lb. The reason for the last category is that such parts would normally require two persons or lifting equipment for handling. Corrected values of handling time for the first weight category (0–30 lb) were obtained by assuming an average weight of 15 lb.

For the second weight category, the part requires two persons to handle. The figures for this category were obtained by estimating the time for two persons to acquire a part weighing 45 lb, doubling this time, and multiplying the result by a factor of 1.5. This factor allows for the fact that two persons working together will typically only manage to work in coordination for 67% of their time.

For the third weight category, where lifting equipment is needed, allowance must be provided for the time taken for the worker to acquire the equipment, use it to acquire the part, move the part to the assembly, release the part, and finally return the lifting equipment to its original location. Figure 3.52 gives the estimated times for these operations, assuming that no increase in the size of the assembly area was required in order to accommodate the lifting equipment. These estimates were obtained using the MOST time standard system [21] and included the times required to acquire the equipment, move it to the parts'

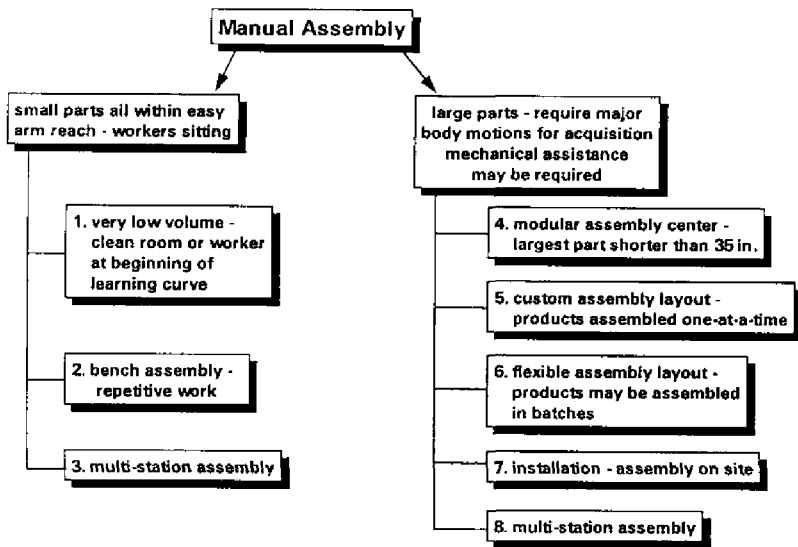

FIG. 3.51 Manual assembly methods.

location, hook the part, transport it to the assembly, unhook the part, and, finally, return the equipment to its original location.

For small parts, where several are required and can be grasped in one hand, it will usually be advantageous to acquire all the needed parts in one trip to the storage location. Figure 3.54 presents the results of an experiment where the effect of the distance traveled by the assembly worker on the acquisition and handling time per part was studied. It can be seen that when the parts are stored out of easy arm reach, it is preferable to acquire all the parts needed in the one trip to the storage location. From results such as these it is possible to estimate acquisition times for the multiple acquisition of parts stored away from the assembly fixture. Figure 3.52 presents these times for each of the product size categories.

In the work [20] leading to the development of Fig. 3.52, the size of the largest part in the product was assumed to determine the size and nature of the assembly area layout. However, to provide an alternative method of identifying the layout size, for each layout an average distance from the assembly to the storage location of the major parts was determined. These averages are listed in the second column in Fig. 3.52 and provide an alternative method for the determination of the appropriate layout.

	average distance to location of parts (ft.)	size of largest part in assembly (in.)	one item (small or large) or multiple small parts				small part – jumbled can be grasped in multiples		
			weight < 30 lbs.		weight > 30 lbs.		additional time per part		
			easy to grasp	difficult to grasp (1)	two persons	manual crane	easy to grasp	difficult to grasp (1)	
			0	1	2	3	4	5	
factory assembled large products (2)	< 4	< 15	0	2.54	4.54	8.82	18.42	0.84	1.11
	4 to 7	15 to 25	1	4.25	6.25	14.34	27.10	0.84	1.11
	7 to 10	25 to 35	2	5.54	7.54	18.54	31.22	0.84	1.11
	10 to 13	35 to 50	3	9.93	11.93	32.76	39.50	0.84	1.11
	13 to 16	50 to 65	4	11.61	13.61	36.75	44.93	0.84	1.11
	> 16	> 65	5	12.41	14.41	40.80	50.07	0.84	1.11

Notes: 1) For large items, no features to allow easy grasping (eg. no finger hold).

For small items, those that are slippery, nested, tangled, or stuck together require careful handling are difficult to grasp.

2) Times are for acquisition only. Multiply by 2 if replacement time is to be included (eg. fixture).

FIG. 3.52 Acquisition times (s) for items not stored within easy reach of the assembly worker. (Copyright Boothroyd Dewhurst, Inc. 1991.)

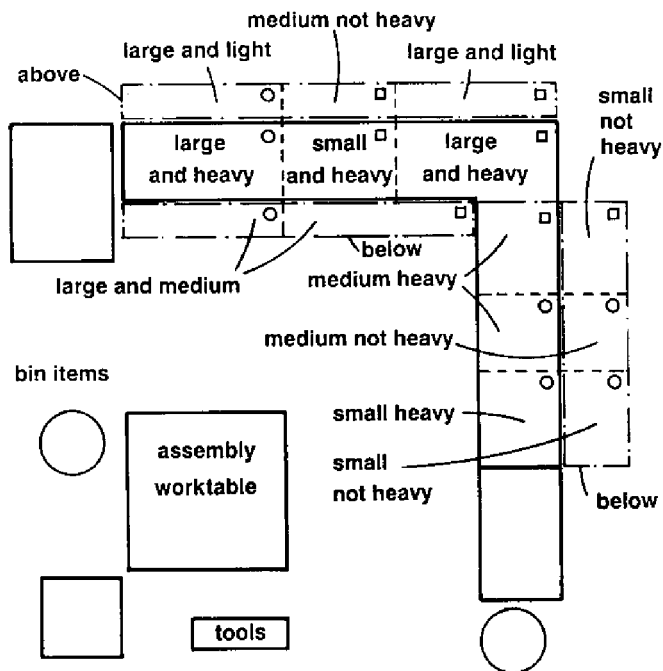

FIG. 3.53 Assumed distribution of parts in custom assembly layout: □, low turnover; ○, high turnover.

3.25 ASSEMBLY QUALITY

The design for assembly procedures described in this chapter have been used by Motorola, Inc., since the mid-1980s. In 1991 Motorola reported the results of a DFA redesign of the motor vehicle adapter for their family of two-way professional hand-held radios [22]. Their benchmarking of competitors' electronic products indicated a best-in-class manual assembly efficiency (DFA index), as given by Eq. (3.1), of 50%, and they evaluated many different concepts to reach that goal. The final design had 78% fewer parts than their previous vehicle adapter and an 87% reduction in assembly time. They also measured the assembly defect rates of the new design in production and compared the results to defect rates for the old design. The result was a 95.6% reduction in assembly defects per product. Encouraged by this result, the Motorola engineers surveyed a number of products that had been analyzed using DFA and produced a relationship between assembly defects per part and the DFA assembly efficiency values.

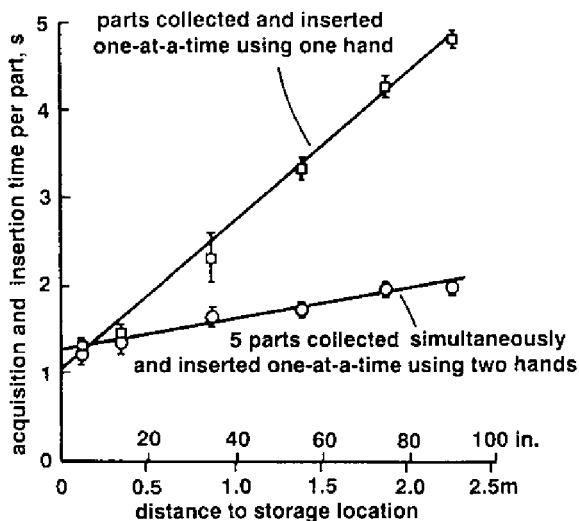

FIG. 3.54 Effects of distance to storage location on the acquisition and assembly time for small parts.

This relationship was discussed in Chapter 1, and as illustrated in Fig. 1.10 shows a strong relationship between assembly quality and the assembly efficiency value of a product.

These Motorola data were subsequently analyzed independently by other researchers [23] to produce an even more powerful relationship for use in early design evaluation. These researchers postulated that since DFA assembly time values are related to the difficulty of assembly operations, then the probability of an assembly error may also be a function of predicted assembly operation times. In the study it was reported that 50 combinations of defect rates versus assembly characteristics were tested for meaningful correlation. Of these, the variation of average assembly defect rate per operation with average DFA time estimate per operation showed the strongest linear correlation, with correlation coefficient $r = 0.94$. The actual data are shown in Fig. 3.55. The equation of the regression line is given by

$$D_i = 0.0001(t_i - 3.3) \quad (3.23)$$

where D_i = average probability of assembly defect per operation
 t_i = average assembly time per operation

As discussed earlier, the average assembly time predicted by the DFA time standard database, for parts which present no assembly difficulties, is approxi-

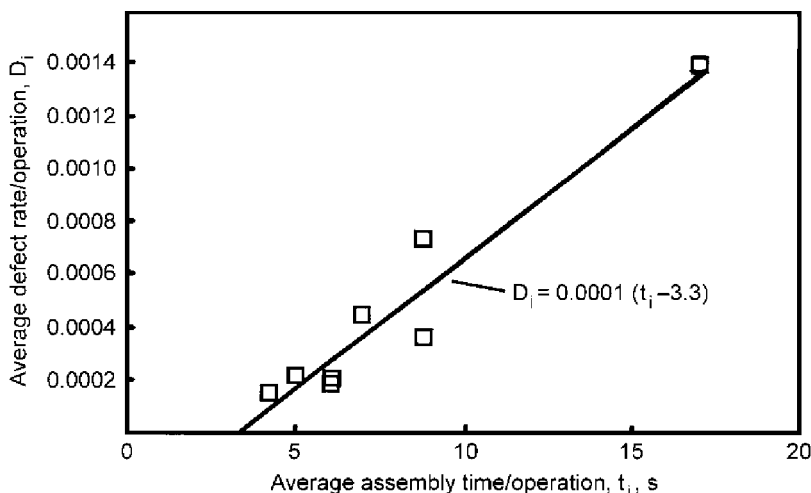

FIG. 3.55 Relation between assembly defect rate and average DEA assembly time. (After Ref. 23.)

mately 3 s. Thus Eq. (3.23) can be interpreted as an estimated assembly defect rate of 0.0001, or 1 in 10,000, for every second of extra time associated with difficulties of assembly. In fact, if the regression line in Fig. 3.55 is constrained to pass through $t_i = 3$, then the correlation coefficient is still 0.94 to two decimal places. For this reason we will use 3.0 instead of 3.3 in the expressions and calculations below.

For a product requiring n assembly operations, the probability of a defective product, containing one or more assembly errors, is therefore approximately

$$D_a = 1 - [1 - 0.0001(t_i - 3.0)]^n \quad (3.24)$$

Alternatively, the expected number of assembly errors in one of these products is given by

$$N_d = 0.0001(t_i - 3.0)n \quad (3.25)$$

These relationships can be applied very easily in the early stages of design to compare the likely assembly error rates of alternative design concepts for small products assembled in large quantities. This can provide powerful directional guidance for product quality improvements, since it is becoming widely accepted that faulty assembly steps, rather than defective components, are more often the reason for production quality problems [24].

For the controller assembly example discussed earlier, the existing design requires 25 operations for final assembly and has a total estimated assembly time,

obtained from the DFA analysis, of 206.43 s; see Fig. 3.37. The average time per operation is thus $206.43/25$, equal to 8.26 s. Applying Eq. (3.24) then gives

$$D_a = 1 - [1 - 0.0001(8.26 - 3.0)]^{25} = 0.0131 \quad (3.26)$$

Thus, the estimated probability of a defective assembly is 0.0131, or 1.31%.

For the redesigned controller assembly, the number of final assembly operations has been reduced to 10, and the estimated assembly time is 77.93 s; see Fig. 3.39. The average time per operation is now 7.8 s, and the likely number of defective assemblies is given by

$$D_a = 1 - [1 - 0.0001(7.8 - 3.0)]^{10} = 0.0048 \quad (3.27)$$

Thus the predicted assembly defect rate is about one-third of that for the original design. This defect rate could be reduced further, by considering detail design improvements to further decrease the average operation time of 7.8 s.

The expression $(t_i - 3.0)n$ in Eq. (3.25) can be interpreted as the total time penalty associated with the assembly of a product. For example, for the original design of the controller assembly, the 25 assembly operations would take only 75.0 s if there were no assembly difficulties. The total assembly time penalty is $(8.25 - 3.0) 25$, equal to 131.4 s. Equation (3.25) thus predicts that the assembly defects per unit will be proportional to the total assembly time penalty. This interpretation is supported by another set of industrial quality data illustrated in Fig. 3.56. These data were obtained from a disk drive manufacturer [25], and it

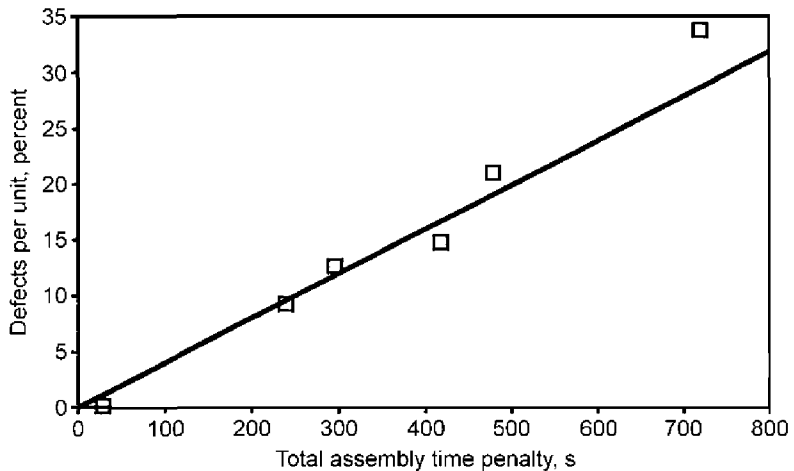

FIG. 3.56 Relation between total DFA assembly time penalty and assembly defect rates per unit. (After Ref. 26.)

should be noted that one outlier with a defect rate of approximately 65% has been omitted from the figure. It should also be noted that the slope of the regression line in Fig. 3.56 is approximately 0.0004. This suggests that the assembly workers are making mistakes at four times the rate of those involved in building the Motorola products. This may be the result of the delicate nature of disk drive assemblies and the need to maintain very small clearances in these devices.

3.26 APPLYING LEARNING CURVES TO THE DFA TIMES

Learning-curve theory applied to industrial production has its roots in early aerospace manufacturing. A now-famous paper by T. P. Wright [26] resulted from the study of small aircraft construction in the 1920s and 1930s. Wright noted that as repetitive tasks are performed, improvement occurs at a diminishing rate. In particular, he noted that twice as many repetitions are required to achieve each successive constant incremental improvement. This constant improvement with doubling is embodied in a simple power law, referred to as the Wright model, which is expressed as

$$T_{1,x} = T_1 x^b \tag{3.28}$$

where

- $T_{1,x}$ = average time of production for x units
- T_1 = time of production for the first unit
- x = number of identical units
- b = the reduction exponent

The reduction exponent can, in turn, take the general form

$$b = \log r / \log f \tag{3.29}$$

where

- r = the average time for a factor increase in output divided by the time for the first output expressed as a percentage
- f = the factor increase in output

Normally a doubling of output is the basis for learning curve analyses, and the improvement is given as r percent. For this case Eq. (3.29) becomes

$$b = \log(r/100) / \log 2 \tag{3.30}$$

For example, the often-quoted 90% learning curve represents the situation where the average time to produce $2x$ units will be 90% of the average time taken to produce the first x of those units. From Eq. (3.30) this gives

$$b = \log 0.9 / \log 2 = -0.152$$

Note that if b is known, then the learning curve percent value is given by the inverse of Eq. (3.30)

$$r = 2^b 100\% \quad (3.31)$$

Other forms of learning curve have been proposed and used since the work of Wright; see Refs. [27] and [28]. In particular, in cases where the times for producing successive individual units are of primary interest a more appropriate model may be represented by

$$T_x = T_1 x^c \quad (3.32)$$

where

T_x = time to produce the x th unit

x = number of identical units

c = "individual" reduction exponent

This alternative model is attributed to Crawford [29], whose work was carried out for Lockheed Aircraft Corporation. For batch assembly work the Wright model is more appropriate and will be used below to calculate learning-curve adjustments to predicted assembly times.

The reduction exponent represents the improvements that would be expected as the worker "learns" to operate more efficiently through repetitive identical tasks. However, Eq. (3.28) can be viewed in a much broader sense as a progress function that models progress accomplished through improved process techniques, tools, and training methods, as well as the learning associated with repetitions of the same task [30]. For these situations a learning-curve percentage value of 85 is more appropriate than the 90% value typically used to model worker performance improvement only [27].

The learning-curve equations described above can be used to adjust DFA times for situations in which only a few assemblies are to be produced. To carry out this adjustment, the number of task repetitions, for which the DFA times apply, must first be established. Since the handling and insertion experiments used to obtain the DFA times were mainly based on 100 task repetitions, this number will be used as the basis for the example calculations below. In other words, it will be assumed that DFA times are equivalent to $T_{1,100}$ times on the appropriate learning curve. We can thus make learning-curve transformations, using the Wright model, as follows:

$$T_{1,100} = T_1 100^b \quad (3.33)$$

or

$$T_1 = T_{1,100} / 100^b \quad (3.34)$$

Thus for the first assembly of a small batch B of products, the average time will be given by the Wright model as

$$T_{1,B} = T_1 B^b \quad (3.35)$$

Finally, substituting from Eq.(3.34) for T_1 gives

$$T_{1,B} = T_{1,100}(B/100)^b \quad (3.36)$$

where

b = reduction exponent

$T_{1,B}$ = adjusted DFA time for batch size B

B = total batch to be assembled

$T_{1,100}$ = assumed basic DFA time value

Example: A set of only five measuring instruments is to be produced. A DFA analysis shows an estimated assembly time given by T_A . Using a 90% learning curve, provide an estimate for the average time to build the first two units. Use this value to determine the average time to assemble the next three units. Assume that the DFA time estimate would apply well for the average assembly time of 100 units.

- (a) Substituting T_A for $T_{1,100}$ in Eq. (3.36) and using $b = -0.152$ for a 90% learning curve gives

$$T_{1,2} = (2/100)^{-0.152} T_A = 1.81 T_A \quad (3.37)$$

- (b) The predicted assembly time for all five units is given by

$$5 \times T_{1,2} = 5(5/100)^{-0.152} T_A = 7.88 T_A \quad (3.38)$$

Similarly the total time for the first two units is

$$2 \times T_{1,2} = 2(2/100)^{-0.152} T_A = 3.62 T_A \quad (3.39)$$

Thus, the average time for units 3, 4, and 5 can be given by

$$T_{3,5} = (7.88 - 3.62) T_A / 3 = 1.42 T_A \quad (3.40)$$

REFERENCES

1. Boothroyd, G., Product Design for Assembly, Department of Mechanical Engineering, University of Massachusetts, Amherst, 1980.
2. Boothroyd, G., Design for Economic Manufacture, Annals CIRP, Vol. 28, No. 1, 1979, p. 345.
3. Yoosufani, Z., and Boothroyd, G., Design of Parts for Ease of Handling, Report No. 2, Department of Mechanical Engineering, University of Massachusetts, September 1978.

4. Boothroyd, G., Design for Manual Handling and Assembly, Report No. 4, Department of Mechanical Engineering, University of Massachusetts, Amherst, September 1979.
5. Yoosufani, Z., Ruddy, M., and Boothroyd, G., Effect of Part Symmetry on Manual Assembly Times, *J. Manuf. Syst.*, Vol. 2, No. 2, 1983, pp. 189–195.
6. Seth, B., and Boothroyd, G., Design for Manual Handling, Report No. 9, Department of Mechanical Engineering, University of Massachusetts, January 1979.
7. Ho, C., and Boothroyd, G., Avoiding Jams During Assembly, *Machine Des.*, Tech. Brief, January 25, 1979.
8. Ho, C., and Boothroyd, G., Reducing Disc-Assembly Problems, *Machine Des.*, Tech. Brief, March 8, 1979.
9. Ho, C., and Boothroyd, G., Design of Chamfers for Ease of Assembly, Proc. 7th North American Metalworking Conference, May 1979, p. 345.
10. Fujita, T., and Boothroyd, G., Data Sheets and Case Study for Manual Assembly, Report No. 16, Department of Mechanical Engineering, University of Massachusetts, Amherst, April 1982.
11. Yang, S.C., and Boothroyd, G., Data Sheets and Case Study for Manual Assembly, Report No. 15, Department of Mechanical Engineering, University of Massachusetts, Amherst, December 1981.
12. Dvorak, W.A., and Boothroyd, G., Analysis of Product Designs for Ease of Manual Assembly: A Systematic Approach, Report No. 11, Department of Mechanical Engineering, University of Massachusetts, Amherst, May 1982.
13. De Lisser, W.A., and Boothroyd, G., Analysis of Product Designs for Ease of Manual Assembly: A Systematic Approach, Report No. 17, Department of Mechanical Engineering, University of Massachusetts, Amherst, May 1982.
14. Ellison, B., and Boothroyd, G., Applying Design for Assembly Handbook to Reciprocating Power Saw and Impact Wrench, Report No. 10, Department of Mechanical Engineering, University of Massachusetts, Amherst, August 1980.
15. Karger, W., and Bayha, F.H., *Engineered Work Measurement*, Industrial Press, Inc., New York, 1966.
16. Raphael, David L., A Study of Positioning Movements, Research Report No. 109, MTM Association of Standards and Research, Ann Arbor, Michigan, 1957 and 1967.
17. Quick, Joseph H., *Work Factor Time Standards*, McGraw-Hill, New York, 1962.
18. Raphael, D.L., A Study of Arm Movements Involving Weight, Research Report No. 108, MTM Association of Standards and Research, Ann Arbor, Michigan 1955 and 1968.
19. Karge, D.W., and Hancock, W.M., *Advanced Work Measurement*, H.B. Maynard & Co., Pittsburgh, 1982.
20. Fairfield, M.C., and Boothroyd, G., Part Acquisition Time During Assembly of Large Products, Report No. 44, Department of Industrial and Manufacturing Engineering, University of Rhode Island, 1991.
21. Zandin, K.B., *MOST Work Measurement Systems*, 2nd ed., Marcel Dekker, New York, 1989.
22. Branam, W., DFA Cuts Assembly Defects by 80%, *Appliance Manufacturer*, November 1991.
23. Barkan, P., and Hinckley, C.M., The Benefits and Limitations of Structured Design Methodologies, *Manufacturing Rev.*, Vol. 6, No. 3, September 1993.
24. Hinckley, C.M., *The Quality Question, Assembly*, November 1997.
25. Hinckley, C.M., *Global Conformance Quality Model*, Sandia National Laboratory Report SAND94-8451, 1994.

26. Wright, T.P., Factors Affecting the Cost of Aeroplanes, *J. Aeronaut. Sci.*, Vol. 3, 49–73, 1936.
27. Teplitz, C.J., *The Learning Curve Deskbook*, Quorum Books, Westport, CT, 1991.
28. Belkaoni, A., *The Learning Curve: A Management Accounting Tool*, Greenwood Press, Westport, CT, 1986.
29. Crawford, J.R., *Learning Curve, Ship Curve, Ratios, Related Data*, Lockheed Aircraft Corporation, Burbank, CA.
30. Kniep, J.G., The Maintenance Program Function, *J. Ind. Eng.*, November–December, 1965.